

SERVICE MANUAL



SANGO ADVANCED

Sango Advanced R

Sango Advanced F

Sango Advanced M

Sango Advanced Junior R

Sango Advanced Junior F

Sango Advanced Junior M

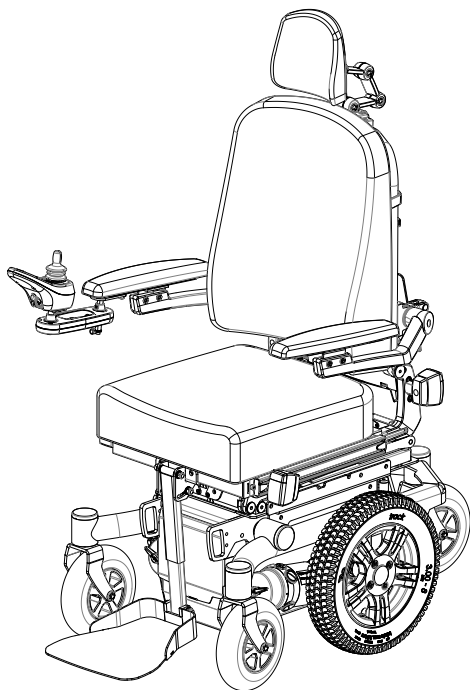
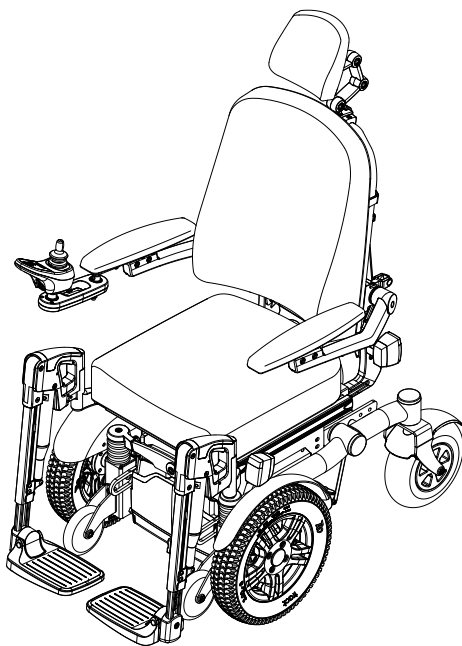

SANGO SLIMLINE

Sango Slimline M

Sango Slimline Junior M

© 2017 DIETZ-Power BV

All rights reserved.

The information provided may in no way be reproduced and/or published in any form or by any means (electronically or mechanically) without the express prior written consent of DIETZ-Power BV.

The information provided is based on general data pertaining to constructions known at the time of issue. DIETZ-Power BV pursues a policy of continuous product development and therefore reserves the right to make changes.

The information provided applies to the standard version of the product. DIETZ-Power BV can therefore not be held liable for any damage resulting from specifications deviating from the standard version of the product.

The information made available has been compiled with the greatest care. However, DIETZ-Power BV cannot be held liable for any errors in the information or for the consequences thereof. DIETZ-Power BV cannot be held liable for any damage resulting from work carried out on the wheelchair by third parties.

Under legislation relating to the protection of trademarks, those commercial names, trade names, trademarks, etc. used by DIETZ-Power BV may not be regarded as being free of rights.

Table of contents

1	Preface	5
1.1.	About this manual	5
1.2.	Symbols used in this manual	5
1.3.	Service, support and ordering	6
2	Safety.....	7
2.1.	Safety guidelines	7
2.2.	Temperature	7
2.3.	Moving parts	8
2.4.	Electromagnetic radiation	8
2.5.	Markings on the wheelchair	9
3	Maintenance and tools	10
3.1.	Maintenance plan	10
3.2.	Tools	11
3.3.	Driving programs	12
4	Replacements and adjustments	13
4.1.	Preparation	13
4.2.	Carrier	14
4.3.	Dahl preparation	18
4.4.	Interface (all types)	20
4.5.	Legrests	22
4.6.	Seating system	23
4.7.	Control system	24
5	Wiring and diagrams	25
5.1.	Connecting wires	25
5.2.	Electrical diagrams VR2	26
5.3.	Electrical diagrams R-net	27
5.4.	Connect the batteries	28
6	Troubleshooting.....	29
6.1.	Wheelchair functionality table	29
6.2.	Seat adjustments	34

7	Technical specifications	35
7.1.	Standards and requirements	35
7.2.	Specifications operating force	35
7.3.	Specifications Sango Advanced Segó Comfort	36
7.4.	Specifications Sango Slimline Segó Comfort	37
7.5.	Specifications Sango Advanced Segó Junior	38
7.6.	Specifications Sango Slimline Segó Junior	39
7.7.	Specifications batteries	40
7.8.	Electrical diagrams	40
8	Warranty conditions	41
8.1.	Warranty period	41
8.2.	Warranty provisions	42
8.3.	Warranty procedure	42

1 Preface

1.1. About this manual

The service manual contains information and instructions about general maintenance and repairs of the powered wheelchair for:

- Qualified service technicians that perform the maintenance and solves technical problems of the wheelchair.
- DIETZ-Power dealers who support customers when they call the dealer's office with questions about the wheelchair. This service manual will serve as reference material to help the customer service employee.

Other available manuals:

- The general user manual of the wheelchair.
- The user manual for the controller.
- The user manual for the battery.
- The spare part manual.
- The technical manual from the supplier of the controller.

Warning!

Read through all the manuals carefully before performing any maintenance or repairs on the wheelchair. Always follow the safety guidelines!





1.2. Symbols used in this manual

Warning

Follow the instructions given under warnings! Failure to exercise due care in following these instructions may result in physical injury, damage to the wheelchair or damage to the environment. Where possible, the warnings are given in the section that is most relevant.

Cross-reference symbol

Where required, this service manual makes reference to the other manuals. This is done in the following way:

-  WHEELCHAIR: Please refer to the general user manual for the wheelchair.
-  CONTROLLER: Please refer to the user manual for the controller.
-  BATTERY: Please refer to the user manual for the battery.
-  SPARES: Please refer to the spare part manual
-  TECHNICAL: Please refer to the technical manual from the supplier for the controller.

1.3. Service, support and ordering

For information concerning specific settings, maintenance or repairs please contact your supplier. He is always prepared to help you.

Ensure you have the following information at hand (see 2.4 Identification plate):

- Type of the wheelchair
- Year of manufacture
- Identification number

For ordering spare parts please use the spare part manual to see what part number you need and how to order.

2 Safety

All of the very latest information relating to product safety and any product recalls can be found on our website at www.DIETZ-Power.com.

Warning

Follow the instructions given under warnings! Failure to exercise due care in following these instructions may result in physical injury, damage to the wheelchair or damage to the environment.

2.1. Safety guidelines

Warning

- We advise you to contact our service department before you do repairs to a wheelchair that has been involved in an accident.
- Maintenance and repairs may only be carried out by trained and authorised service technicians. Temporary employees and persons in training may only carry out repair and replacement work under the supervision of an authorised service technician.
- Only do maintenance on an empty chair, without user.
- Always make sure that you work safely, particularly when you need to lift up the wheelchair.
- DIETZ-Power will deliver a wheelchair with default factory settings. These settings depend on the options ordered with the wheelchair. When a configuration is ordered that causes interference, DIETZ-Power applies modified settings.
- Programming should only be conducted by professionals with in-depth knowledge of wheelchair control systems. Incorrect programming could result in an unsafe set-up of the wheelchair for a user. DIETZ-Power accepts no responsibility for losses of any kind if the programming of the control system is altered without authorization of DIETZ-Power.
- During the execution of maintenance and repairs, the service technician is at all times fully responsible for the fulfilment of locally applicable safety.
- After repairing, reprogramming or replacing parts, always check the functionality of the entire wheelchair. Pay special attention to safety features such as slowdown driving or drive inhibits when seat lift and tilt are both used.

2.2. Temperature

Warning

- Avoid any physical contact with the motors of the wheelchair at all times. When the wheelchair is in use, the motors are in constant motion and can reach high temperatures. Any physical contact with the motors could result in burns. After use, the motors cool down slowly.
- Ensure that the wheelchair is not exposed to direct sunlight for long periods of time when not in use. Some parts of the wheelchair (such as the seat, backrest and armrests) can become hot if exposed to the sun for too long. This may result in burns or skin sensitisation.

2.3. Moving parts

⚠ Warning

Wheelchairs contain moving and rotating parts (figure 1). Contact with moving parts may result in serious physical injury or damage to the wheelchair. You should avoid any contact with the moving parts of the wheelchair.

- A. Wheels (turning and pivoting)
- B. Swing-away controller arm
- C. Powered backrest adjustment
- D. Powered tilt adjustment
- E. Powered leg rests
- F. Powered lift adjustment



2.4. Electromagnetic radiation

The standard version of your powered wheelchair has been tested for compliance with the applicable requirements relating to electromagnetic radiation (EMC requirements).

⚠ Warning

Despite testing, the following cannot be ruled out:

- electromagnetic radiation interfering with the wheelchair. For example mobile telephones, large medical devices or other sources of electromagnetic radiation
- the powered wheelchair interfering with electromagnetic fields. For example shop doors, burglar alarm systems in shops or garage door openers.
- in some configurations equipped with a R-net controller, where it is possible that extreme electrical discharge situations due to static electricity, may cause a fault message ('ISM over-current') flashing on the screen. If this occurs simply turn off your wheelchair for a few seconds and back on to clear the fault.







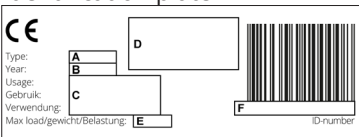

In the unlikely event of such problems arising, please notify your dealer immediately.

2.5. Markings on the wheelchair

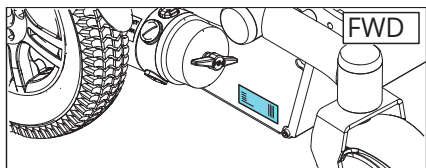
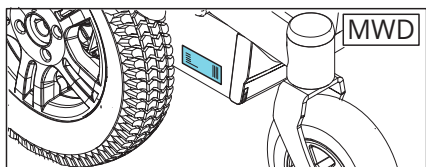
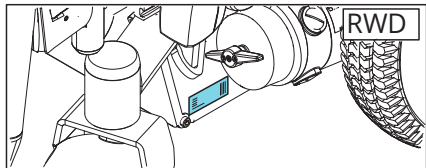
Warning

- The markings, symbols and instructions on the wheelchair are part of the safety features. They must not be covered up or removed. They must remain on the wheelchair and be clearly legible for the whole lifespan of the wheelchair.
- Immediately replace or repair any markings, symbols or instructions that become damaged or illegible. Contact your dealer in such cases.

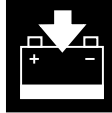
Symbols used on the wheelchair

	<p>Consult the manual before use.</p>	<p>Identification plate</p>  <p>CE Type: A Year: B Usage: C Verwendung: D Max. load/gewicht/Belastung: E F ID-number</p> <p>A. Type B. Year of manufacture C. Usage indoor or outdoor D. Manufacturer E. Maximum load in kg F. Identification number</p>
	<p>Freewheel switch</p> <ul style="list-style-type: none"> • Drive position • Push position <p> Warning Never set the freewheel switch to the 'Push' position when the wheelchair is on a slope.</p>	<p>Location identification plate: on the batterybox at the left side</p>   
	<p> Warning (yellow-black) Pinch point hazard: Keep hands and fingers away from moving parts when adjusting the height and/or tilt angle of the wheelchair.</p>	
	<p>Securing point for transportation inside a vehicle.</p>	
	<p> CONTROLLER Battery charging point.</p>	

3 Maintenance and tools

General guidelines



- Take all the safety guidelines (2.1) into account when carry out any maintenance or repairs to the wheelchair.
- Always handle waste materials according to the local regulations.

3.1. Maintenance plan

The wheelchair must be checked by an authorized service technician on regular basis (at least once a year) and before reuse. Check all parts of the maintenance checklist and make sure the checklist in the end-users manual will be entirely filled after each maintenance.

Use only original DIETZ-Power parts for maintenance and repairs.	
Operation	
<input type="checkbox"/>	Horn
<input type="checkbox"/>	On/off switch
<input type="checkbox"/>	Output plug
<input type="checkbox"/>	Joystick
<input type="checkbox"/>	Brakes
<input type="checkbox"/>	Programme configuration
Batteries	
<input type="checkbox"/>	Level
<input type="checkbox"/>	Connectors
<input type="checkbox"/>	Discharge level
Wheels	
<input type="checkbox"/>	Wear
<input type="checkbox"/>	Pressure
<input type="checkbox"/>	Bearings
<input type="checkbox"/>	Wheel nuts
Motors	
<input type="checkbox"/>	Wiring
<input type="checkbox"/>	Connectors
<input type="checkbox"/>	Noise
<input type="checkbox"/>	Brakes
Remarks:	
Chassis	
<input type="checkbox"/>	Parts tightened
<input type="checkbox"/>	Condition
<input type="checkbox"/>	Controls
Upholstery	
<input type="checkbox"/>	Seating system
<input type="checkbox"/>	Backrest
<input type="checkbox"/>	Armrests
Electronics	
<input type="checkbox"/>	Cable condition
<input type="checkbox"/>	Connectors
Driving	
<input type="checkbox"/>	Forwards
<input type="checkbox"/>	Reverse
<input type="checkbox"/>	Emergency stop
<input type="checkbox"/>	Turning
<input type="checkbox"/>	Uphill/downhill
<input type="checkbox"/>	Obstacles
<input type="checkbox"/>	Parking brake

Batteries

- The wheelchair is fitted with 'dry' gel batteries. The batteries are fully sealed and require no maintenance.
- The use of 'wet' batteries is not permitted. If the batteries have to be replaced, use only dry batteries.
- Batteries contain acids. Damaged batteries are a serious health hazard. Follow the instructions on the batteries at all times.
-  WHEELCHAIR and  BATTERY for additional information.
-  CONTROLLER for the battery wiring diagram

Tyres

Check tyre pressure and inflate if necessary

- Before tyres are repaired they must first be fully deflated.
- Never exceed the maximum tyre pressure.
-  WHEELCHAIR for the right tyre pressure and additional information.

Wheelchair and upholstery

Clean the wheelchair and its upholstery

- Take care with water in view of the electronic system
- For disinfecting spray the chair with alcohol.
-  WHEELCHAIR for additional information.

3.2. Tools

Warning

Use only high-quality tools for the adjustment(s) described.

Tools for mechanical settings

The following tools are needed to do the mechanical settings as described in this manual:

Description	Size* / type
Screwdriver	4x100
Pair of wire cutters	
Open ended spanner	10, 13
Ring spanner	10, 13
Torque wrench, up to 60 Nm with sockets	10, 13
Allen keys	3, 4, 5, 6, 8
Loctite 638	Bolt securing
Loctite 243	Bolt securing
Tie wraps	Black
Hammer (plastic)	

*Size is the EU key width

Tools for electronic settings

The following tools are needed to do the electronic settings as described in this manual:

Part number	Description	R-Net	VR2
	PGDT R-Net programmer OEM (D50611)	x	
	PGDT VR2 PC-Programmer B set (D50145)		x
	Universal meter (voltage and resistance	x	x

Use the torques as indicated in the table below, unless specified otherwise

Thread Size	Pitch (mm)	Max. torque (Nm)
M4	0.7	3
M5	0.8	6
M6	1	10
M8	1.25	25
M10	1.5	50

The minimum torque values are 7 - 9 % below the maximum values.

3.3. Driving programs

Existing driving programs are available on request.

4 Replacements and adjustments

4.1. Preparation

📖 WHEELCHAIR for the most common wheelchair settings (chapter 5).

⚠ Warning!

- Take all the safety guidelines (2.1) into account when carry out any maintenance or repairs to the wheelchair.
- Only do maintenance on an empty wheelchair.

4.1.1. Disconnect the battery and/or motor connector (Slimline)

For some maintenance the battery and/or motor connector needs to be disconnected. There is made a reference to this action where needed:

1. Pull the lips of the battery box (A figure 2) to the side and open the cover (B).
2. Loosen the allen key (C) and slide out the plate with the power module (D).
3. Disconnect the motor connectors (A figure 3) and/or battery connector (B) from the interconnection of the power module.

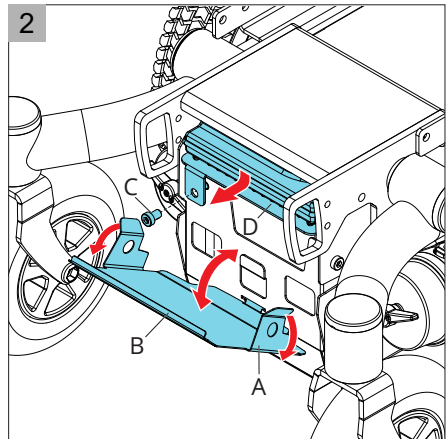

4.1.2. Disconnect the battery and/or motor connector

For some maintenance the battery and/or motor connector needs to be disconnected. There is made a reference to this action where needed:

1. Loosen the two allen keys of the cover between the wheels.
2. Open the cover of the power module
3. Disconnect the motor connectors (A figure 3) and/or battery connector (B) from the interconnection of the power module.

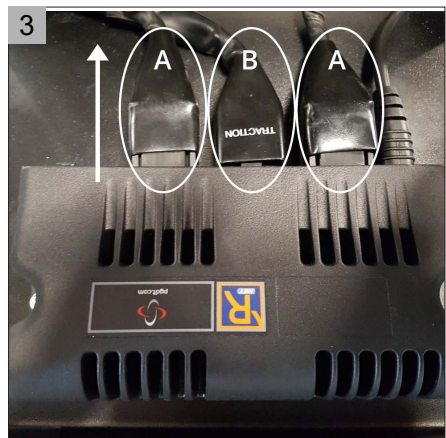

4.2. Carrier

4.2.1. Replace the rubber suspension

1. Follow the preparation (see 4.1).
2. Unscrew the bolt (A figure 4). Make sure the battery box will be supported.
3. Replace the rubber suspension (B).
4. Tighten the bolt.

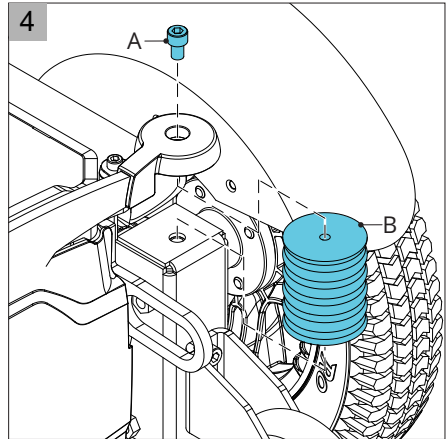

4.2.2. Replace a drive wheel

1. Follow the preparation (see 4.1).
2. Turn off the controller and set both freewheel switches in 'Drive' mode.
3. Lift the wheelchair using a lifting platform until the wheels are free from the floor.
4. Remove the wheel cap (A figure 5).
5. Remove screw B and washer C.
6. Remove the drive wheel (D) from the motor axle. Make sure that you do not lose the key (E).
7. Install the new drive wheel. Make sure the drive wheel does not interfere with the motor.

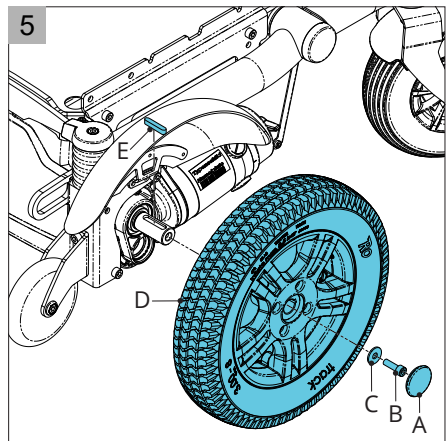

4.2.3. Replace a motor

1. Follow the preparation (see 4.1).
2. Disconnect the battery and motor connectors (see 4.1.1).
3. Remove the drive wheel (see 4.2.1).
4. Loosen the screws (A figure 6) to remove the mudguard (B) for easy access.
5. Remove the 3 bolts (C).
6. Remove the old drive motor (D).
7. Install the new drive motor.

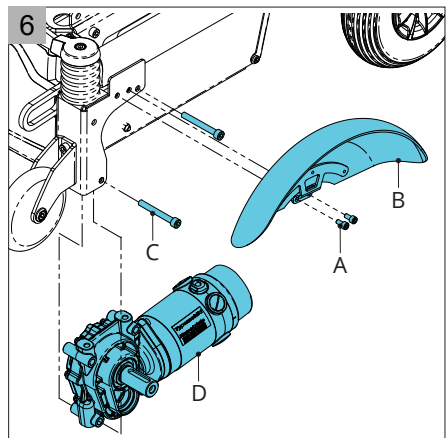

4.2.4. Replace a castor wheel

1. Follow the preparation (see 4.1).
2. Turn off the controller and set both freewheel switches in 'Drive' mode.
3. Lift the wheelchair using a lifting platform until the wheels are free from the floor.
4. Remove the screw, washers and nut (A figure 7).
5. Take out the old castor wheel (B) from the castor fork (C).
6. Install the new castor wheel.
7. Use a new lock nut.

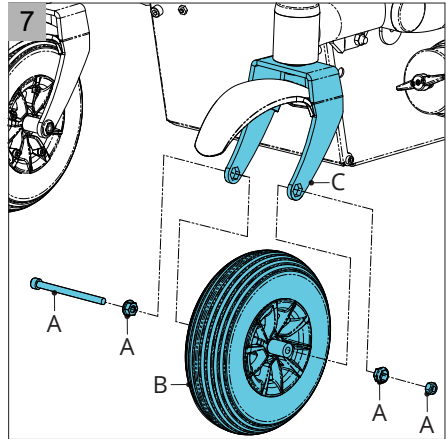
**4.2.5. Replace a castor fork**

1. Follow the preparation (see 4.1).
2. Remove the cap (A figure 8).
3. Unscrew the bolt (B).
4. Remove the castor fork and wheel from the side frame.
5. Unscrew the bolt and nut (C) to remove the castor wheel.
6. If needed unscrew the bolt (D) to remove the mudguard.
7. Mount the new castor fork to the wheel and mount it back on the side frame.

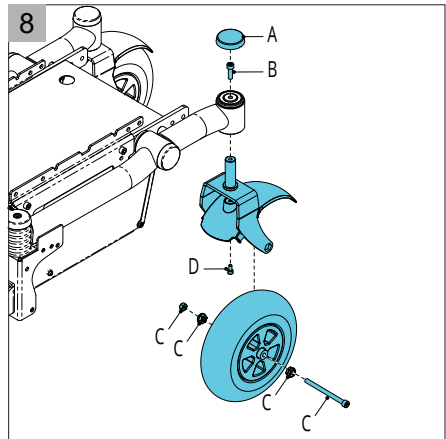

4.2.6. Replacing the anti-shimmy

1. Follow the preparation (see 4.1).
2. Remove the cap (A figure 9).
3. Unscrew the bolt (B).
4. Remove the castor fork and wheel from the side frame.
5. Remove the inner anti-shimmy bush (C) and replace the rubber rings.
6. Mount the castor fork and wheel back on the side frame.

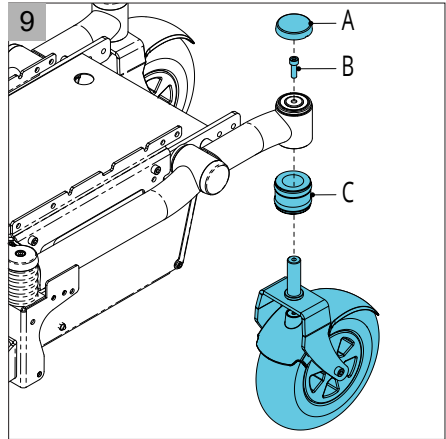

4.2.7. Replace an anti-tip wheel

1. Follow the preparation (see 4.1).
2. Turn off the controller and set both freewheel switches in 'Drive' mode.
3. To replace only the anti-tip wheel (A figure 10): Remove the screw, washers and nut (B).
4. To replace the complete assembly: Remove the screws (C).
5. Install the new parts.

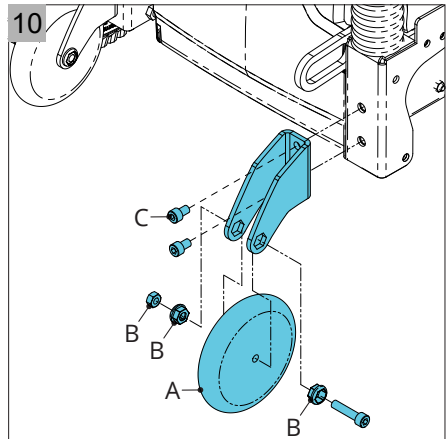

4.2.8. Replace the batteries (Slimline)

1. Follow the preparation (see 4.1).
2. Disconnect the battery connector (see 4.1.1).
3. Loosen the 2 allen screws (A figure 11).
4. Loosen the battery Velcro strap (B)
5. Slide the batteries (C) out of the wheelchair.
6. Disconnect the power cables.
7. Remove the batteries.
8. Put the new batteries in the batterybox.
9. Connect the power cables (see 5).
10. Slide back the batteries into the wheelchair.
11. Tighten the battery Velcro strap.
12. Close the battery cover.

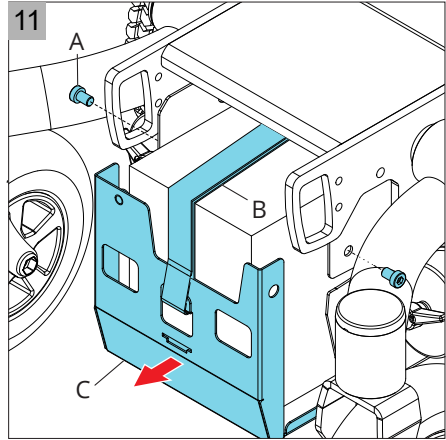

4.2.9. Replace the batteries

1. Follow the preparation (see 4.1).
2. Disconnect the battery connector (see 4.1.1).
3. Open the battery cover.
4. Loosen the screws (A figure 12).
5. Loosen the battery Velcro strap (B).
6. Slide the batteries out of the wheelchair. When 78Ah batteries used, lift up and slide back the batterybox.
⚠ When 78Ah batteries are used, the batteries will drop down 5 cm.
7. Disconnect the power cables.
8. Remove the batteries.
9. Put the new batteries in the batterybox.
10. Connect the power cables (see 5).
11. Slide back the batteries into the wheelchair.
12. Tighten the battery Velcro strap.
13. Close the battery cover.

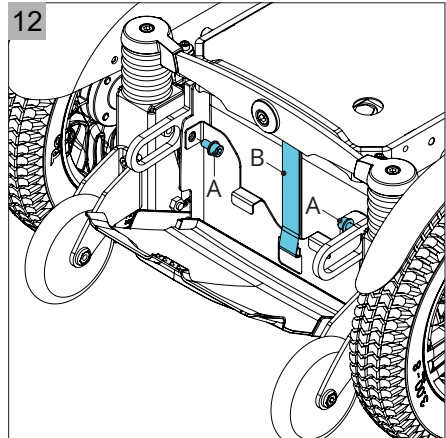

4.2.10. Replace main fuse

The main fuse is located on the battery box.

1. Follow the preparation (see 4.1).
2. Remove the caps and the fuse.
3. Put the new fuse in the fuse holder and put the cap on the holder.

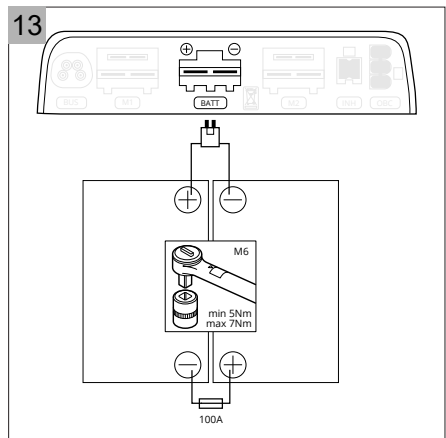

4.3. Dahl preparation

⚠ Warning!

Dahl car docking is not possible in combination with 78Ah batteries.

4.3.1. Replace the slider

To mount the Dahl docking plate the sliders needs to be replaced (side by side).

1. Follow the preparation (see 4.1).
2. Remove the cables if needed
3. Remove the allen screws (A figure 14) and battery cover (B).
4. Remove the allen screw (C) and lower the back part of the seat mounting rail (D).
5. Remove the allen screw (E), the rail holder bracket (F), and hex head screws and rings (G) to remove the sliders with backrest frame out of the seat frame.
6. Remove the lighting (H and L), if applicable
7. Remove the screws and bolts (I) to loosen the sliders (J).
8. Take the nuts (K) from the old slider and place them in the new slider.
9. Mount the lighting with the new (longer) allen screw (L).
10. Mount the sliders and backrest in reverse order.

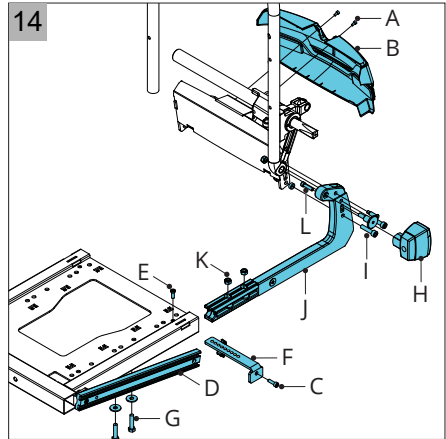

4.3.2. Mounting the Dahl locking plate

⚠ Warning!

- A crash test with Dahl was performed on this wheelchair according to ISO 7176-19 (2008) with a dummy weight of 77 kg.
- The Dahl docking station is only allowed to build into a vehicle by trained and authorized staff of a registered car adaptation company. For ordering the Dahl docking and its accessories, please contact Dahl Engineering in Denmark for further details www.dahlengineering.dk.

To mount the Dahl docking station our preparation kit (📦 SPARES 500062) and the following Dahl parts are needed:

- 500561 Docking plate (C)

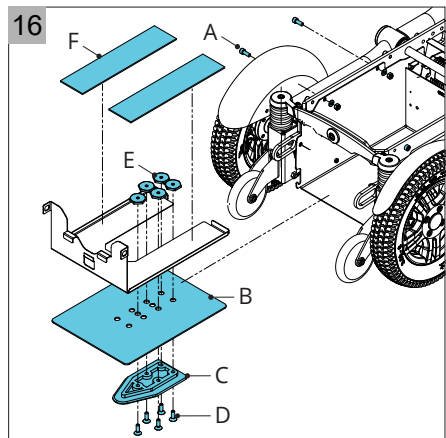
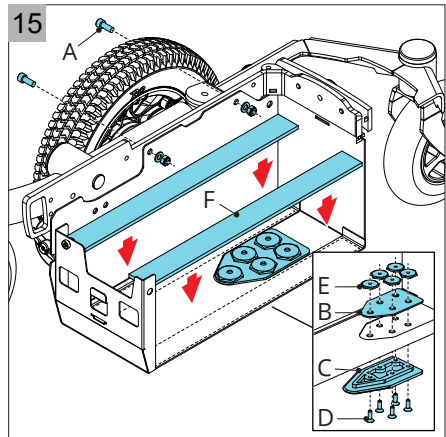

- 502800 High grade steel Torx 27 bolts M8 Quality 14.9 (D)
1. Follow the preparation (see 4.1).
 2. Remove the battery slide plate and the batteries.
 3. Mount the battery box fixation screws 4x (Slimline A figure 15 other products figure 16).
 4. Position the Dahl support plate (B) in the battery box.
 5. Mount the Dahl locking plate (C) under the battery box with the special Dahl nuts (E) and the high grade steel Torx bolts (D) through the Dahl support plate and the dedicated holes in the chassis (figure 17).

⚠ Warning!

- The Dahl high grade steel Torx bolts (D) only come in one length which is often too long. They need to be cut into the right length by the authorized engineer to fit the locking plate properly without damaging the batteries.
 - Do not use any other M8 bolt to replace 502800. They will not be strong enough. The bolt length must be such that they are flush with the upper side of the hexagon nuts (502186). The thread may neither protrude beyond the hexagon nuts or be too short to achieve their full holding force in the thread.
6. Add Loctite 222 onto the thread of the high grade Torx bolts to secure them and tighten them with a torque wrench to the preset torque of 16-18Nm
 7. Position the two plastic spacers (F) in the battery slide plate.
 8. Place the batteries and the battery slide plate back in the battery box.

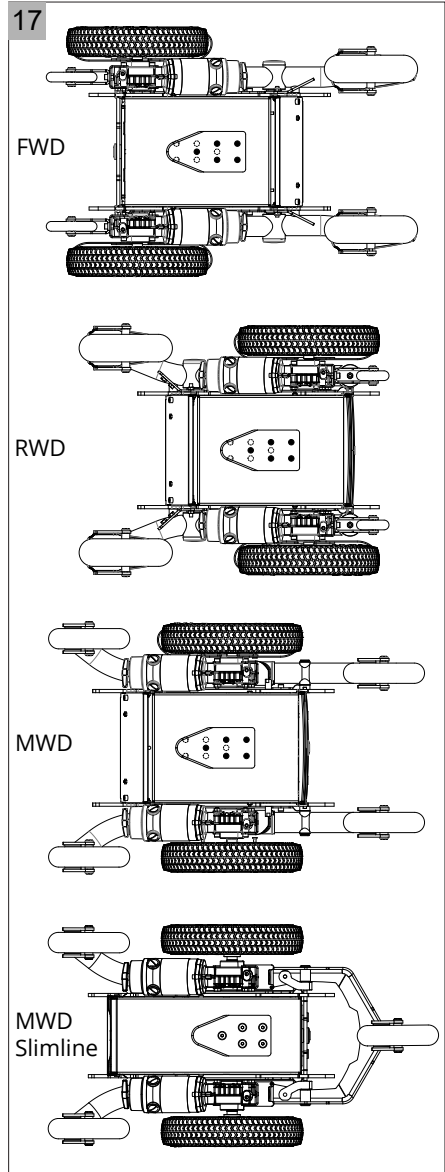

4.4. Interface (all types)

4.4.1. Adjust the centre of gravity (not recommended)

The position of the interface can be adjusted in order to give the wheelchair better driving characteristics. This position depends on the seat depth and the drive type.

1. Follow the preparation (see 4.1).
2. Set the interface in the maximum tilted position for easy access.
3. Disconnect the interface cables from the controller.
4. Remove the screws (Junior A figure 18 other products figure 19) (4x).
5. Move the interface (B) to the desired new position.
6. Fasten the screws (4x).
7. Check if the wheelchair is stable in all available positions for seat lift and tilt.

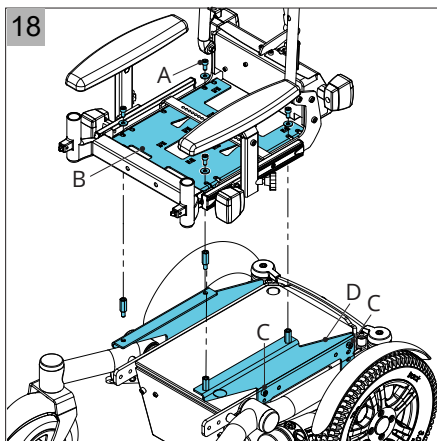

4.4.2. Adjust the height of the seat interface (not recommended)

The height of the interface can be adjusted in order to achieve the seat height as required for the user.

1. Follow the preparation (see 4.1).
2. Remove the screws (Junior A figure 18 other products figure 19) to remove the interface including the seating system from the wheelchair carrier, for easy access.
3. Remove the 2 screws (C) on both sides.
4. Slide the interface bracket (D) into the desired height.
5. Put the screws into one of the 4 holes to and thighten the screws.
6. Put the interface including seating system back on the wheelchair carrier.
7. Check if the wheelchair is stable in all available positions for seat lift and tilt.

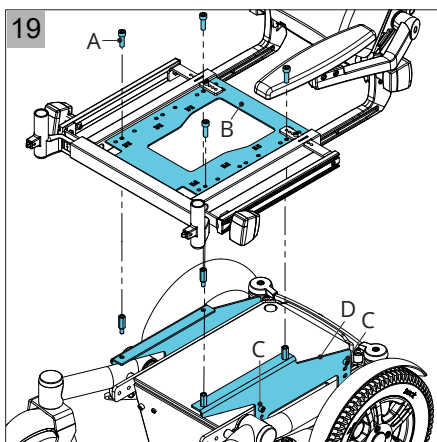

4.4.3. Replace the tilt or lift-tilt module

1. Follow the preparation (see 4.1).
2. Loosen the 2 allen screws (A figure 20) and remove the cover (B).
3. Loosen the cable tray and disconnect the cables.
4. Loosen the 4 allen screws (A figure 21) and remove the seating frame from the chassis.
5. Loosen the 4 hexagon heads (B) and 4 allen screws (C) to remove the tilt or lift-tilt module.
6. Place and mount the new module and seating frame back to the chassis.
7. Connect all cables (see 5).

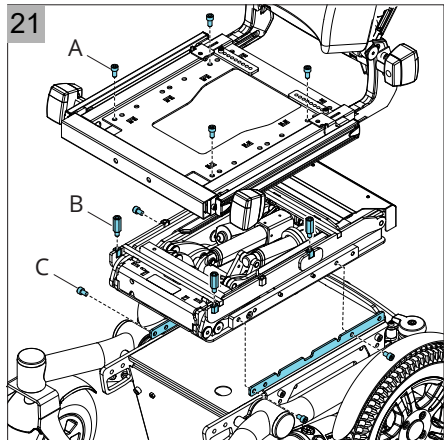
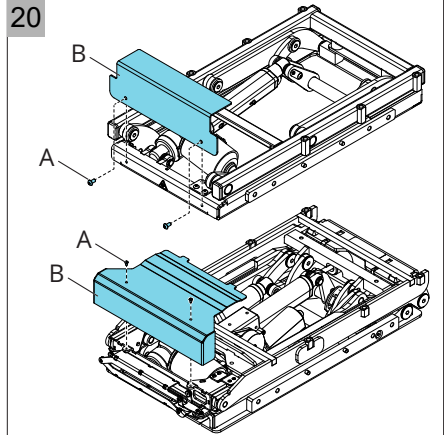

4.5. Legrests

4.5.1. Replace the actuator of a powered legrest

1. Follow the preparation (see 4.1).
2. Lift the legrest out of the wheelchair.
3. Remove the tie wraps and disconnect the actuator cable from the legrest.
4. Remove the screws and bushes (A figure 22).
5. Remove the old actuator (B).
6. Put the new actuator in the legrest.
7. Connect the actuator cable.
8. Put the connector cable into the groove of the legrest and fasten the connector cable with tie wraps.
9. Make sure that you leave enough free cable length to let the actuator reach its full length.
10. Check the functionality of the actuator.

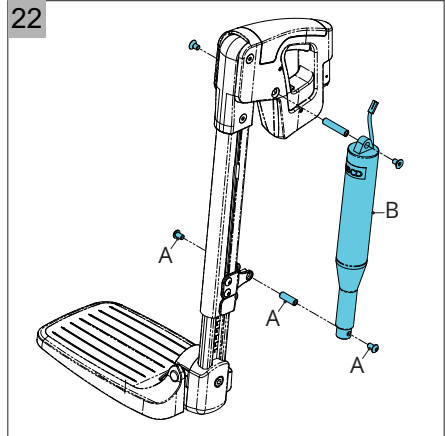

4.5.2. Replace the gasspring of a comfort legrest

1. Follow the preparation (see 4.1).
2. Lift the legrest out of the wheelchair.
3. Remove the screws and nuts (A figure 23).
4. Remove the old actuator (B) from the legrest.
5. Remove the lever block from the gasspring. The lever block is re-used with the new gasspring.
6. Put the level block on the new gasspring.
7. Put the new actuator in the legrest.
8. Check the functionality of the actuator.

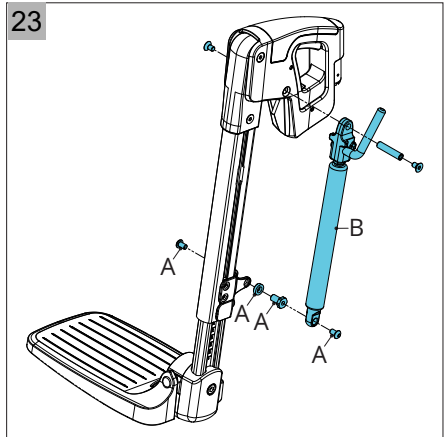

4.5.3. Replace the actuator for angle function of the central legrest

1. Follow the preparation (see 4.1).
2. Disconnect the cable (A figure 24).
3. Loosen the 2 allen screws (B) to remove the calf plates.
4. Loosen the C-clip (C) and the allen screw (D) and move the shaft (E) until the actuator comes free.
5. Mount the new actuator in reverse order and check the functionality.

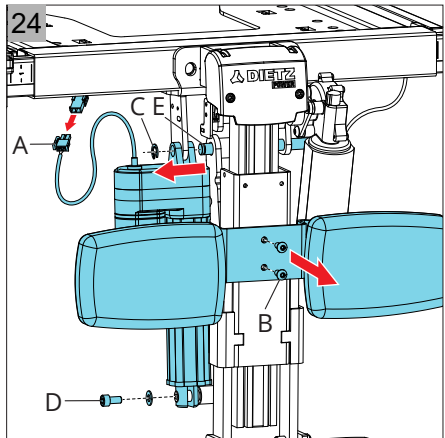

4.5.4. Replace the motor for transfer function of the central legrest

1. Follow the preparation (see 4.1).
2. Put the legrest in an angle of 90°.
⚠ Support the footplate to prevent the length compensation belt from rolling.
3. Disconnect the cable (A figure 25).
4. Loosen the 2 allen screws (B) to remove the calf plates.
5. Loosen the 3 allen screws (C) to remove the motor.
6. Mount the new motor in reverse order and check the functionality

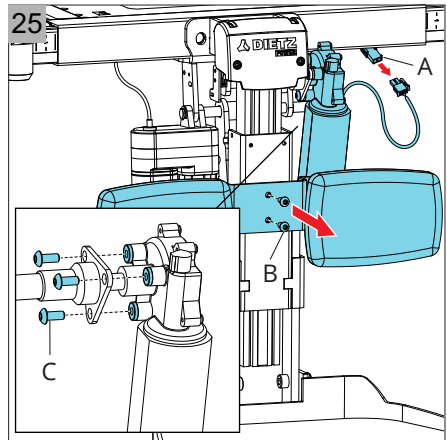

4.6. Seating system

4.6.1. Replace the actuator of the backrest

1. Follow the preparation (see 4.1).
2. Remove the ISM cover.
3. Disconnect the ISM connector.
4. Remove the 4 bolts (Junior A figure 26 other products figure 27) and bushes (B).
5. Remove the old actuator (C) from the backrest frame.
6. Put the new actuator in the backrest frame.
7. Check the functionality of the actuator.

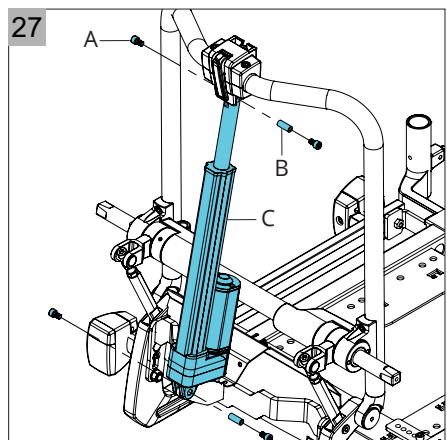
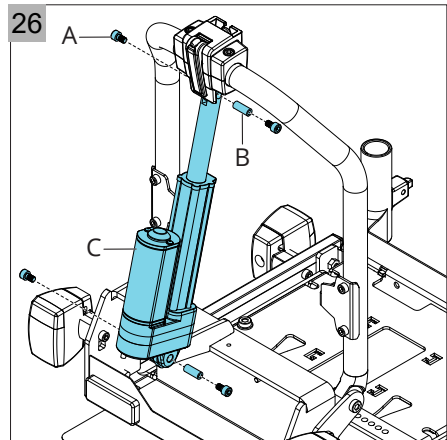

4.7. Control system

The driving program of the VR2 and R-Net controller systems is stored in the power module. Replacing the remote control can therefore be done without any programming.

4.7.1. Replace the remote control

1. Follow the preparation (see 4.1).
2. Loosen the two screws (A figure 28).
3. Disconnect the power cables.
4. Put the new remote control (B) on the bracket.
5. Tighten the screws.
6. Connect the power cables.

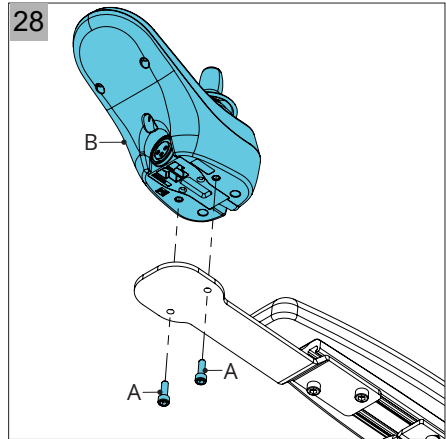

4.7.2. Replace the power module (Slimline)

1. Follow the preparation (see 4.1).
2. Make a backup of the driving program from the power module. Use a laptop and programming software for this step.
3. Access the powermodule as described in 4.1.1.
4. Loosen the two allen screws (A figure 29) and replace the power module (B).
5. Load the backup of the driving program in to the new power module.
6. Check all functionalities of the wheelchair.

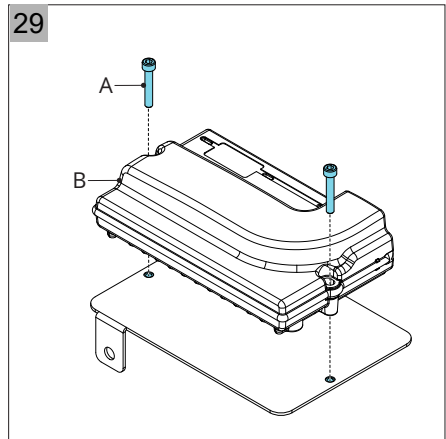

4.7.3. Replace the power module

1. Follow the preparation (see 4.1).
2. Make a backup of the driving program from the power module. Use a laptop and programming software for this step.
3. Loosen the two allen screws (A figure 30) and open the power module cover.
4. Loosen the two screws (B) and replace the power module (C).
5. Load the backup of the driving program in to the new power module.
6. Check all functionalities of the wheelchair.

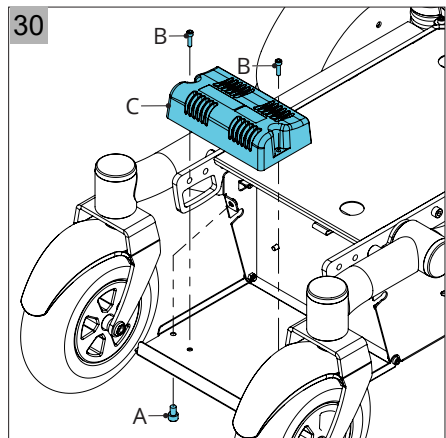

5 Wiring and diagrams

5.1. Connecting wires

When connecting the wires, check the following:

- Fix the wires with tie wraps to the seat to prevent entrapment of loose wires between parts.
- Ensure that the wires are not trapped under the seat.
- Replace wires immediately if they are damaged, because of possible risks when wires are broken or electrical breakdown.
- Never attempt to repair any damaged wires but replace them with original wires.
- Keep the actuator adjustments in mind when routing the wires (eg tilt). There has to be enough cable length to make the electrical adjustment possible. This is why there will be an overlength of the cable in use with the 45° tilt. In case of the lift the wires needs to be fitted in the cable track.
- Never roll up or cross loop the overlength wires to prevent EMC. Better practice is to route the wires up and down and keep the open loops next to each other.
- Take minimum bending radius into account when tracking routes and securing wires. Do not take too sharp turns.
- Do not pull wires tight over sharp corners or edges of the construction since this may damage the cables.
- Make sure the wires are not too tight and/or under tension.
- Check all above points after each width, depth or height adjustment made to the chair.

5.2. Electrical diagrams VR2

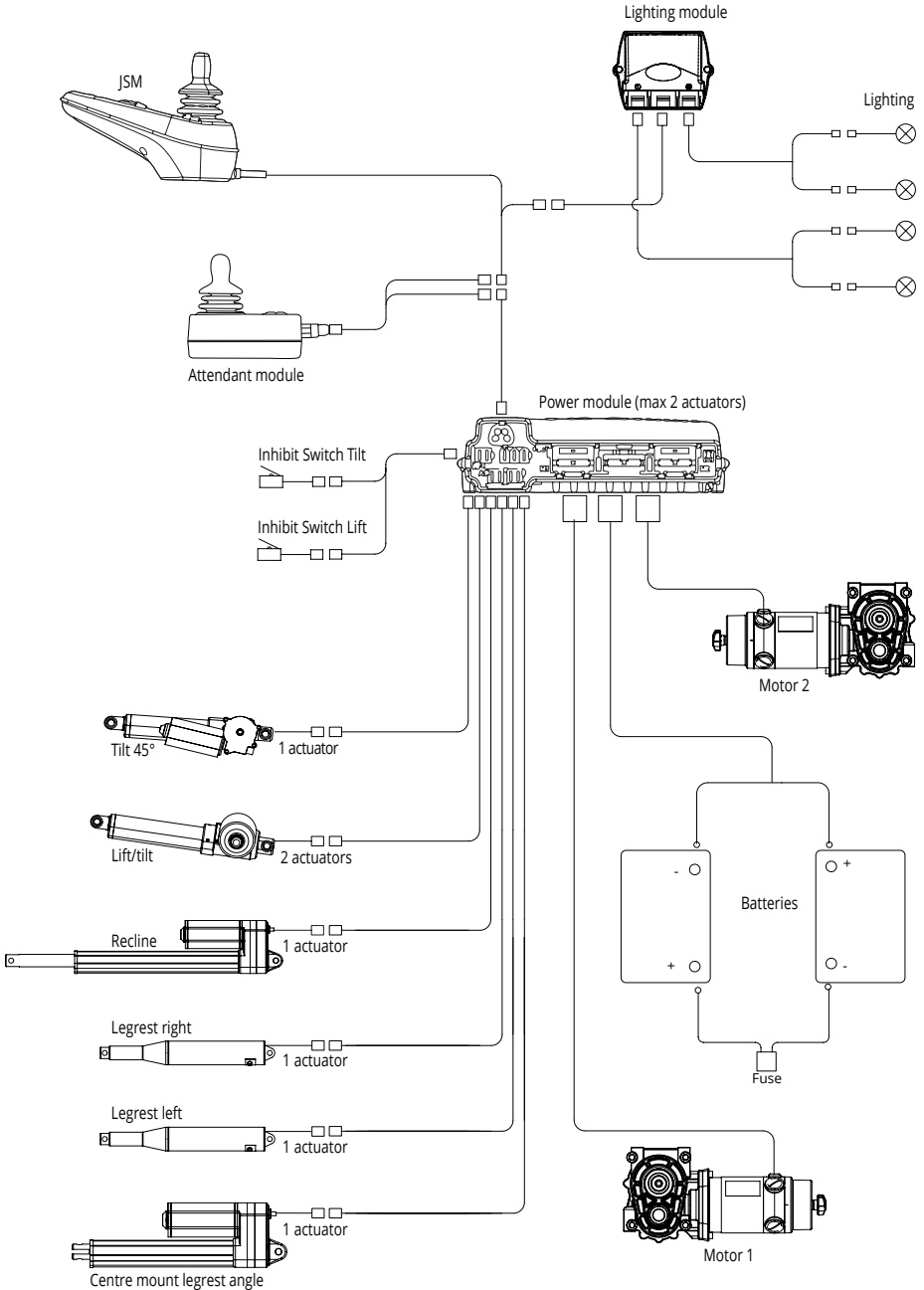

5.3. Electrical diagrams R-net

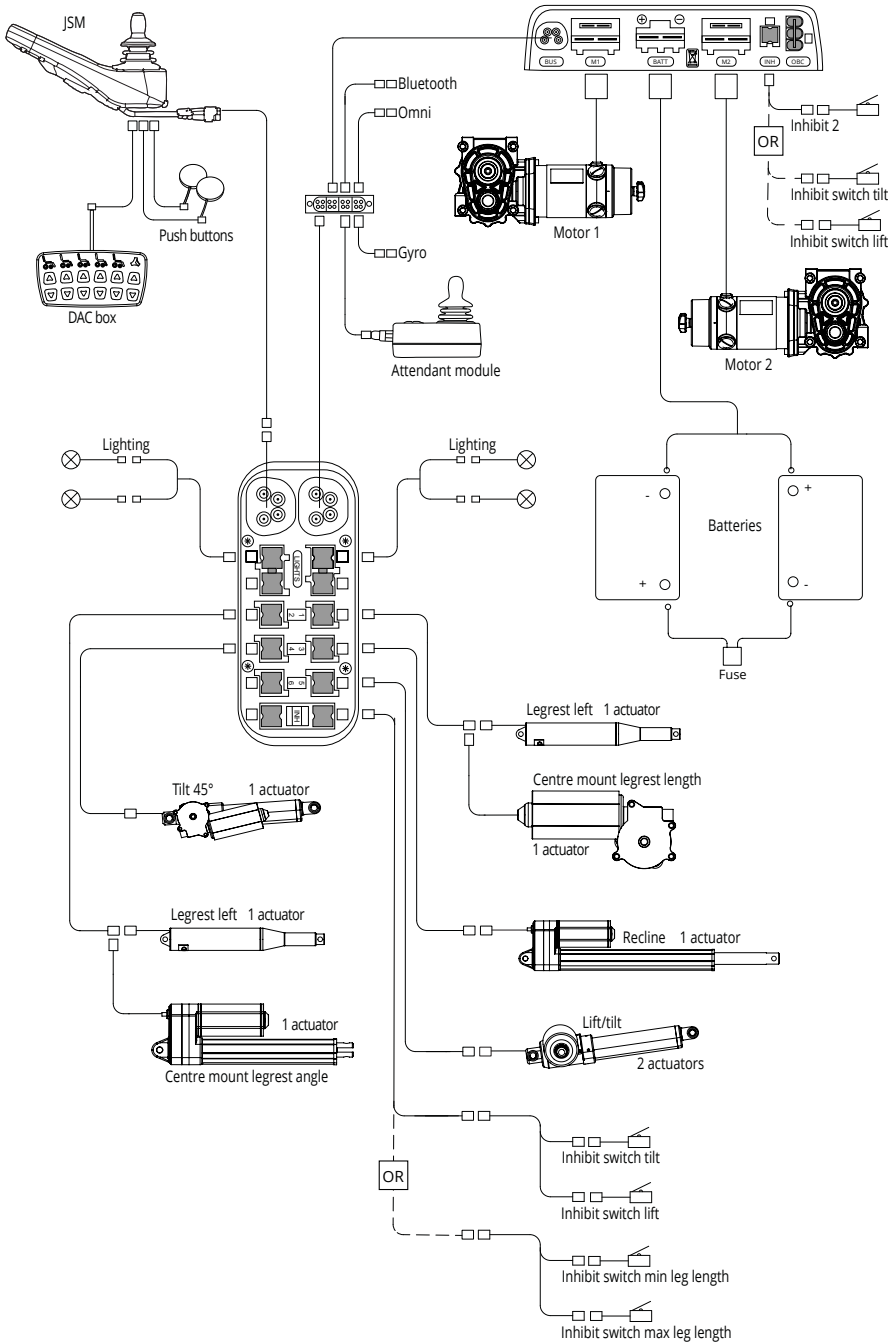

5.4. Connect the batteries

See figure 26 how to connect the battery charger.

The controller includes a '3-pin connection'. Ensure that the battery charger is properly connected so that the 'negative pole' and the 'inhibit' are connected, enabling the system to prevent the wheelchair from moving when the battery is being charged (figure 27).

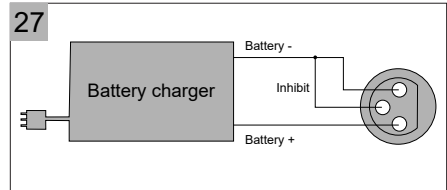
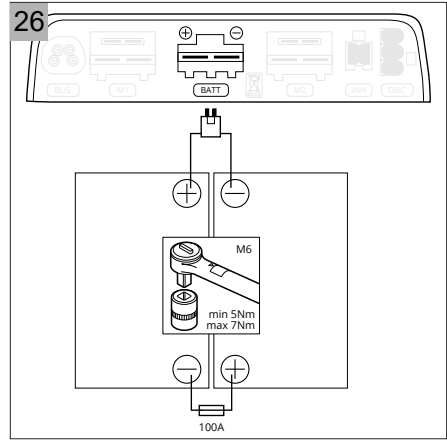

6 Troubleshooting

If the wheelchair will not function while the batteries are fully charged, check the following points:

- Switch the controller off and then switch it on again. Check to see if the wheelchair functions again.
-  **WHEELCHAIR** Check if the free wheel switch is switched to drive.
- Check if the joystick was in the neutral position when the controller was switched on. In other words, the joystick must not be moved when the controller is being switched on or off.
- Check whether all the battery clips are firmly in place.

If your wheelchair is still not working, or is not working as it should, go through the wheelchair functionality table in the following paragraph.

 **TECHNICAL** in case of controller issues for more detailed information. The R-net and VR2 technical manuals can be downloaded at the www.pgdt.com or www.DIETZ-Power.com website.

Warning!

Before changing bus cables, fuses and/or modules, remove both fuses from the battery compartment, so the system will be 'dead'.

6.1. Wheelchair functionality table

A. Wheelchair does not switch on	
Cause	Possible solution
Buscables not connected	Check buscable connections of the joystick module to the power module (can also be through the actuator module!)
Pins in connectors are loose or damaged	Check connectors for loose or damaged pins. If damaged replace cable.
Buscable defect	Check all bus cables for damage. Bypass each buscable with new one to check functionality.
Fuse defect / Thermal trip	Check fuses and replace if needed.
Battery connections are loose	Check battery connections and restore if needed.
Battery voltage too low	Measure battery voltage and charge batteries.
Battery defect	Measure battery voltage. Voltage below 10 V can indicate that one battery is defect. Replace batteries.
Remote control or button defect	Check by replacing with new one.
Power Module defect	Check by replacing with new one.

B. Wheelchair continuously drives slower than normal	
Cause	Possible solution
Speed limit due to microswitch signal from seating function.	Check if all seating options are in neutral position. Measure resistance from the speed limit cable in different seating positions. Bad cable connections or a broken resistor influences the drive inhibit signal.
Incorrect programming	Check for correct program. Re-program if needed.
Parking brake partially engaged	Check parking brake function. Clicking sound at engaging/disengaging should be present. Check temperature of parking brake after driving.

C. Wheelchair drives slower throughout the day (or after several hours)	
Cause	Possible solution
Poor batteries	Check batteries and battery voltage.
Poor or incomplete battery charging	Check battery charger. Check charging duration with the user.
Thermal rollback (overheating)	Check usage of wheelchair, extreme usage can cause the power module to decrease the maximum currents for protection.
	Check wheelchair in freewheel mode for extreme resistance on rolling or turning.
	Check Gyro cabling and/or replace Gyro module.

D. Wheelchair only drives well for a short period of time	
Cause	Possible solution
Current limit is set too low or the controller is underspecified	Check program settings and/or replace controller.

E. Wheelchair can be powered up, but does not drive	
Cause	Possible solution
Parking brakes are in freewheel mode (flash code on remote)	Set parking brakes to Drive mode.
Drive inhibits active (flash code on remote)	Check program which Drive inhibits are present. Check cabling of Drive inhibits on wheelchair.

F. Wheelchair has too little power to drive properly	
Cause	Possible solution
Tyre pressure of drive wheels or castors is too low	Check pressure and inflate if needed. See User manual for correct value.
Programming of speed and Torque Settings is not correct	Check programming and make corrections if needed.
Programming of Motor Load Compensation is not correct	Check programming and make corrections if needed. Check with manufacturer for correct value.

G. Wheelchair veers to one side	
Cause	Possible solution
Programming of Load Compensation is not correct.	Check programming and make corrections if needed.
Motors are not "balanced"	Check motor rpm. See motor label for correct value.
Tyre pressure or tyre size left and right are different	Check tyre pressure and tyre size (diameter).
Suspension "hardness" left and right are different.	Check suspensions and make sure left and right side have identical suspension rates.
Carrier is not "in balance" due to mechanical flaws	Check for loose bolts, cracked or worn frame parts. Check height of carrier left and right.
User weight is not in the center of the wheelchair	Check position of user, see if position can be improved. If not possible use veer compensation in program to correct the steering.
Chair stops intermittently	High Voltage due to overcharging or driving down slopes with full batteries (regenerative braking). Check battery voltage, drive down slope at lower speed.
Worn carbon brushes	Check brushes, replace if needed.
Speed Limit due to micro switch	Check functioning of micro- switch. Due to vibrations or shocks it can temporarily switch to Slowdown mode.

H. Castor wheels "wobble" at higher speed	
Cause	Possible solution
Tyre pressure too high.	Check tyre pressure and decrease if needed. See user manual for correct value.
Too little load on the castor wheels.	Modify seating setup if possible or decrease tyre pressure.

I. Motors make excessive noise	
Cause	Possible solution
Worn carbon brushes	Check carbon brushes and collector. If needed replace brushes or motor.

J. Wheelchair wobbles overall or moves up and down when driving	
Cause	Possible solution
Drive wheels have radial misaligned tyres. Can be caused by long (weeks) inactive periods	Check for misalignment of tyres. If misaligned, reduce tyre pressure to 1 bar, drive for several minutes at moderate speed and increase pressure again to advised value. Misalignment can be reduced this way. If not sufficient replace wheel.

K. Seating actuator does not function	
Cause	Possible solution
Current setting is not correct	Check programming and make corrections if needed. Contact manufacturer for correct settings.
Cables not connected or cables damaged	Check cables and replace if needed.
Wheelchair goes into fault status when actuator is operated	Actuator has a short circuit that becomes active when the actuator is operated. Replace actuator.
Actuator inhibit is active	Check program to see what actuator inhibit is present. Check if inhibit signal is functioning correctly (example: with lift and tilt to maximum, recline will no longer move backwards).
Actuator module (output) fault	Try actuators on different output channel to check what output channel has a fault.

L. Seating actuator only functions for a short time	
Cause	Possible solution
Maximum current setting is too low	Check programming and make corrections if needed. Contact manufacturer for correct settings.
Actuator time out setting is too short (or actuator speed is too low)	Check programming and make corrections if needed. Contact manufacturer for correct settings.
Actuator is internally not functioning properly	Check actuator temperature after operation and/or check for excessive noise when operated. Replace actuator.
Seating mechanism is moving poorly or with extreme friction	Check mechanism on loose bolts, cracked or bent parts. Replace parts or modules.

M. Seating actuator moves in wrong direction (after replacement)	
Cause	Possible solution
Wiring connections possibly twisted in cable or motor	Change actuator direction in driving program or replace cable or part.

N. Lighting does not function	
Cause	Possible solution
Cabling not (correctly) connected	Check cabling. See wiring diagrams for correct connections.
Lighting settings not correctly set in program	Check programming and make corrections if needed.

O. Wheelchair moves/turns very slowly and seems to be lacking power	
Cause	Possible solution
Load compensation too low, incorrect setting.	Modify load compensation in driving program. Check with manufacturer for correct settings.
Too much load on front castors (RWD).	Modify seating setup to have better weight distribution.

P. Wheelchair moves very rapidly and jerky	
Cause	Possible solution
Load compensation is too high.	Modify load compensation in driving program. Check with manufacturer for correct settings.

Q. Castor wheels shimmy at higher speeds (≥ 10 km/h)	
Cause	Possible solution
The anti-shimmy set does not function properly.	Change the rubber rings.
Not enough pressure on the castor wheels.	In case of a light-weight user, it might help to set the CoG setting of the seating system a little more towards the castors. This will result in more pressure on the castor wheels. Note; adjustment of the seating system should always be done with caution, since incorrect weight distribution might negatively affect drive performance and comfort.
High tire pressure (air castors only).	The tires can be inflated up to 3.5 bar. In case of shimmy problems it might help to lower the tire pressure of the castor wheels (min. 1.5 bar). Note; This is not a preferred solution. Lower tire pressure will result in more friction between the wheel and ground. This can cause problems when turning on carpet and can have a negative effect on the range.

If the problem is not solved with the help of the solutions in the tables, contact DIETZ-Power.

6.2. Seat adjustments

TBD

7 Technical specifications



7.1. Standards and requirements

This product complies with the provisions of the Medical Devices Directive and therefore carries the CE mark.

The wheelchair conforms to the following standards and requirements. This has been verified by independent test institutes.

Standard	Description	Weight of test dummy (kg)		
		Advanced	Slimline	Junior
NEN-EN 12182 (2012)	Assistive products for persons with disability - General requirements and test methods	160	136	-*
NEN-EN 12184 (2014) Class B	Electrically powered wheelchairs, scooters and their chargers - Requirements and test methods	160	136	-*
ISO 7176-19 (2009)	Wheeled mobility devices for use as seats in motor vehicles	102	-*	-*

*pending

Standard	Description
EU directive 93/42/EEC	Applicable requirements as stated in Annex 2
ISO 7176-8	Requirements and test methods for static, impact and fatigue strengths
ISO 7176-9	Climatic tests for powered wheelchairs
ISO 7176-14	Power and control systems for electric wheelchairs - Requirements and test methods
ISO 7176-16	Requirements for resistance to ignition of postural support devices

7.2. Specifications operating force

	Min.	Max.	Unit
Joystick	2,5	3,5	N
Swinging away the controller	20	50	N
Electronic switches	2,1	3,5	N
Parking brake	34,77	44,27	N
Attaching the charger plug	7,8	13,9	N

7.3. Specifications Sango Advanced Sego Comfort

Manufacturer	DIETZ-Power B.V. - Vlamovenweg 12 - 5708 JV Helmond
User weight	max. 160 kg
Class	B

SANGO ADVANCED Specifications*	Type	FWD		RWD		MWD		Unit
		min.	max.	min.	max.	min.	max.	
Overall length incl. leg rest		985	1680	980	1680	1070	-	mm
Overall width		615	700	615	700	615	700	mm
Overall height excl. headrest		1010	1340	1010	1340	1010	1340	mm
Transport length incl. leg rest		985		980		1150		mm
Transport width		615		615		615		mm
Transport height		650		650		650		mm
Total mass incl. batteries**		154,5		155		158,5		kg
Mass of the heaviest part		110		110,5		114		kg
Static stability downhill***		10 / 17,5		10 / 17,5		10 / 17,5		° / %
Static stability uphill***		10 / 17,5		10 / 17,5		10 / 17,5		° / %
Static stability sideways***		10 / 17,5		10 / 17,5		10 / 17,5		° / %
Theoretical distance range****		30		30		30		km
Dynamic stability uphill		6 / 10,5		6 / 10,5		6 / 10,5		° / %
Obstacle climbing*****		50		50		50		mm
Forward speed		6 / 10 / 12,5		6 / 10 / 12,5		6 / 10 / 12,5		km/h
Braking distance at maximum speed		1	2,9	1	2,9	1	2,9	m
Seat plane angle		0 / 4 / 8		0 / 4 / 8		0 / 4 / 8		°
Effective seat depth		420	560	420	560	420	560	mm
Effective seat width		420	540	420	540	420	540	mm
Seat surface height at front		390	480	390	480	390	480	mm
Backrest angle		90	120	90	120	90	120	°
Backrest height		500	570	500	570	500	570	mm
Footrest to seat distance		380	550	380	550	380	550	mm
Leg rest to seat surface angle		10	75	10	75	10	75	°
Armrest to seat distance		220	350	220	350	220	350	mm
Turning radius*****		620		815		420		mm
Safe slope		6 / 10,5		6 / 10,5		6 / 10,5		° / %
Ground clearance*****		60		60		60		mm
Seat cushion weight		1,6	3,4	1,6	3,4	1,6	3,4	kg
Backrest cushion weight		1,5	2,5	1,5	2,5	1,5	2,5	kg
Leg rest weight		2	4,2	2	4,2	2	4,2	kg
Headrest weight		2,5	2,8	2,5	2,8	2,5	2,8	kg
Measured sound level		63,2		63,2		63,2		dB

7.4. Specifications Sango Slimline Sego Comfort

Manufacturer	DIETZ-Power B.V. - Vlamovenweg 12 - 5708 JV Helmond
User weight	max. 136 kg
Class	B

SANGO SLIMLINE Specifications*	Type	RWD		MWD		Unit
		min.	max.	min.	max.	
Overall length incl. leg rest		980	1680	1070	1265	mm
Overall width		530	700	530	700	mm
Overall height excl. headrest		1010	1340	1010	1340	mm
Transport length incl. leg rest		980		1070		mm
Transport width		530		530		mm
Transport height		650		650		mm
Total mass incl. batteries**		137,5		135		kg
Mass of the heaviest part		93		90,5		kg
Static stability downhill***		10 / 17,5		10 / 17,5		° / %
Static stability uphill***		10 / 17,5		10 / 17,5		° / %
Static stability sideways***		10 / 17,5		10 / 17,5		° / %
Theoretical distance range****		30		30		km
Dynamic stability uphill		6 / 10,5		6 / 10,5		° / %
Obstacle climbing*****		50		50		mm
Forward speed		6 / 10		6 / 10		km/h
Braking distance at maximum speed		1	2,9	1	2,9	m
Seat plane angle		0 / 4 / 8		0 / 4 / 8		°
Effective seat depth		420	560	420	560	mm
Effective seat width		420	540	420	500	mm
Seat surface height at front		410	480	410	480	mm
Backrest angle		90	120	90	120	°
Backrest height		500	570	500	570	mm
Footrest to seat distance		380	550	380	550	mm
Leg rest to seat surface angle		10	75	10	75	°
Armrest to seat distance		220	350	220	350	mm
Turning radius*****		625		420		mm
Safe slope		6 / 10,5		6 / 10,5		° / %
Ground clearance*****		60		60		mm
Seat cushion weight		1,6	3,4	1,6	3,4	kg
Backrest cushion weight		1,5	2,5	1,5	2,5	kg
Leg rest weight		2	4,2	2	4,2	kg
Headrest weight		2,5	2,8	2,5	2,8	kg
Measured sound level		63,2		63,2		dB

7.5. Specifications Sango Advanced Sejo Junior

Manufacturer	DIETZ-Power B.V. - Vlamovenweg 12 - 5708 JV Helmond
User weight	max. 65 kg
Class	B

SANGO ADVANCED Specifications*	Type	FWD		RWD		MWD		Unit
		min.	max.	min.	max.	min.	max.	
Overall length incl. leg rest		985	1680	980	1680	1070	-	mm
Overall width		615	700	615	700	615	700	mm
Overall height excl. headrest		910	1240	910	1240	910	1240	mm
Transport length incl. leg rest		985		980		1150		mm
Transport width		615		615		615		mm
Transport height		650		650		650		mm
Total mass incl. batteries**		144,5		145		148,5		kg
Mass of the heaviest part		100		100,5		104		kg
Static stability downhill***		10 / 17,5		10 / 17,5		10 / 17,5		° / %
Static stability uphill***		10 / 17,5		10 / 17,5		10 / 17,5		° / %
Static stability sideways***		10 / 17,5		10 / 17,5		10 / 17,5		° / %
Theoretical distance range****		30		30		30		km
Dynamic stability uphill		6 / 10,5		6 / 10,5		6 / 10,5		° / %
Obstacle climbing*****		50		50		50		mm
Forward speed		6 / 10 / 12,5		6 / 10 / 12,5		6 / 10 / 12,5		km/h
Braking distance at maximum speed		1	2,9	1	2,9	1	2,9	m
Seat plane angle		0 / 4 / 8		0 / 4 / 8		0 / 4 / 8		°
Effective seat depth		300	400	300	400	300	400	mm
Effective seat width		320	370	320	370	320	370	mm
Seat surface height at front		390	480	390	480	390	480	mm
Backrest angle		90	120	90	120	90	120	°
Backrest height		300	400	300	400	300	400	mm
Footrest to seat distance		320	420	320	420	320	420	mm
Leg rest to seat surface angle		10	75	10	75	10	75	°
Armrest to seat distance		195	280	195	280	195	280	mm
Turning radius*****		620		815		420		mm
Safe slope		6 / 10,5		6 / 10,5		6 / 10,5		° / %
Ground clearance*****		60		60		60		mm
Seat cushion weight		1,4	2,9	1,4	2,9	1,4	2,9	kg
Backrest cushion weight		1,3	2,1	1,3	2,1	1,3	2,1	kg
Leg rest weight		2	4,2	2	4,2	2	4,2	kg
Headrest weight		2,5	2,8	2,5	2,8	2,5	2,8	kg
Measured sound level		63,2		63,2		63,2		dB

7.6. Specifications Sango Slimline Sego Junior

Manufacturer	DIETZ-Power B.V. - Vlamovenweg 12 - 5708 JV Helmond
User weight	max. 65 kg
Class	B

SANGO SLIMLINE Specifications*	Type	RWD		MWD		Unit
		min.	max.	min.	max.	
Overall length incl. leg rest		980	1680	1070	1265	mm
Overall width		530	700	530	700	mm
Overall height excl. headrest		910	1240	910	1240	mm
Transport length incl. leg rest		980		1070		mm
Transport width		530		530		mm
Transport height		650		650		mm
Total mass incl. batteries**		127,5		125		kg
Mass of the heaviest part		83		80,5		kg
Static stability downhill***		10 / 17,5		10 / 17,5		° / %
Static stability uphill***		10 / 17,5		10 / 17,5		° / %
Static stability sideways***		10 / 17,5		10 / 17,5		° / %
Theoretical distance range****		30		30		km
Dynamic stability uphill		6 / 10,5		6 / 10,5		° / %
Obstacle climbing*****		50		50		mm
Forward speed		6 / 10		6 / 10		km/h
Braking distance at maximum speed		1	2,9	1	2,9	m
Seat plane angle		0 / 4 / 8		0 / 4 / 8		°
Effective seat depth		300	400	300	400	mm
Effective seat width		320	370	320	370	mm
Seat surface height at front		410	480	410	480	mm
Backrest angle		90	120	90	120	°
Backrest height		300	400	300	400	mm
Footrest to seat distance		320	420	320	420	mm
Leg rest to seat surface angle		10	75	10	75	°
Armrest to seat distance		195	280	195	280	mm
Turning radius*****		625		420		mm
Safe slope		6 / 10,5		6 / 10,5		° / %
Ground clearance*****		60		60		mm
Seat cushion weight		1,4	2,9	1,4	2,9	kg
Backrest cushion weight		1,3	2,1	1,3	2,1	kg
Leg rest weight		2	4,2	2	4,2	kg
Headrest weight		2,5	2,8	2,5	2,8	kg
Measured sound level		63,2		63,2		dB

7 Technical specifications

- * Specifications were measured with 9» and 14» wheels, powered legrests and in most extreme positions (for min. most stripped version and max. most extended version)
- ** Measured with powered legrest, lift/tilt module and powered backrest.
- *** Measured with the powered adjustments in the neutral position. With the powered adjustments in the most extreme positions the specifications will be 9° / 15.8%.
- **** The following will have a negative impact on the operating range: obstacles, rugged terrain, driving up or down slopes, temperatures below freezing point and frequent use of powered options.
- ***** Specifications mentioned are measured with the max user weight (160 kg).
- ***** Measured without legrest. The turning radius for the MWD with central legrest will be 26 cm more.

7.7. Specifications batteries

Battery capacity	Advanced 50 Ah	Slimline 60 Ah	Advanced 68 Ah	Advanced 78 Ah	Unit
Battery dimensions (w x d x h)	199 x 166 x 171	225 x 136 x 177	258 x 168 x 175	258 x 168 x 210	mm
Battery weight, set	14,8 (±2%)	29,6	43	48,4	kg
Maximum charging current	10	8	8	12	A
Maximum charging voltage	15	24	24	24	VDC
Connector type	📖 CONTROLLER				
Insulation	Class 2 double insulated				

7.8. Electrical diagrams

📖 CONTROLLER for the battery diagram

📖 SERVICE for the electrical wiring diagram (see 5).

8 Warranty conditions

Dealers and/or users have statutory (legal) rights in relation to the purchase of consumer products. The warranty conditions applying to products/parts sold by DIETZ-Power B.V. are set out below. The warranty applies to any product/part that becomes defective or needs to be repaired or replaced as the result of a manufacturing fault or material defect within the stated warranty period.

Term	Definition
Manufacturer	The warranty provider: DIETZ-Power B.V. Vlamovenweg 12 5708 JV Helmond The Netherlands
Dealer	the other party with which DIETZ-Power B.V. enters into a Contract for the (re)sale of Products, on the basis of a distribution agreement or otherwise
User	the party by whom the Products are intended to be used;
Warranty period	Duration of the warranty
Product/part	The product or part supplied by DIETZ-Power B.V.
Option/accessory	Part supplied along with the original product as an add-on to the standard model.
Reserve part	Durable part bought after the original product was purchased.
Wear part	Part subject to natural wear under normal usage.

8.1. Warranty period

The warranty period starts on the date the manufacturer supplies the product/part to the dealer. The warranty period shall not be extended following repair.

Product/part	Warranty period
Frame/assembly, including supplied options and accessories	2 years
Drive system	1 year
Electronics, such as the controller and electronic components	1 year
Reserve parts	1 year from invoice date
Wear parts, including upholstery	40 days from invoice date
Batteries	 BATTERY
Tyres	no warranty

8.2. Warranty provisions

The manufacturer shall not provide any warranty if:

- the product has been passed on to a different owner. The warranty applies only to the first owner to whom the manufacturer supplied the product/parts. The warranty is not transferable and applies only to those models bought from the manufacturer;
- the product/part is damaged as a result of carelessness, an accident or improper use;
- the product/part has not been maintained in accordance with the maintenance instructions stated in the user manual;
- non-original parts have been used;
- the original type plate is no longer attached to the product;
- external/internal changes have been made to the product features. If a dealer wants to modify a product/part contrary to the instructions given in the user manual, the dealer must first consult with the manufacturer;
- force majeure, such as flooding or fire, is involved.

If the provisions stated provide no resolution, the manufacturer's decision shall be final.

8.3. Warranty procedure

If a defect is identified in a product or part and it needs to be sent to the manufacturer, the dealer must fill in the returns form in full. The returns form will be used as the guiding document for the whole warranty procedure.

Procedure for making claims under the warranty:

- If a product/part becomes defective or needs to be repaired or replaced, the user should contact his/her local dealer. The dealer can then make a claim under the warranty if required.
- On identifying the defect, the dealer informs the manufacturer immediately, providing full information relating to the nature of the defect affecting the product/part supplied by the manufacturer;
- If it is possible for the warranty claim to be dealt with by telephone or e-mail and the manufacturer deems the warranty claim to be legitimate, the dealer and the manufacturer consult with each other to determine whether the manufacturer will send a replacement product or part to the dealer free of charge. In such cases, the dealer must
 - destroy the defective product/part on the instructions of the manufacturer.
 - Alternatively, the defective product/part must be returned to the manufacturer. In the case of a return, the manufacturer shall be responsible for arranging and paying for transport;
- If it is not possible to deal with a warranty claim by telephone or e-mail, the dealer and the manufacturer consult with each other to determine:
 - whether the dealer should send the defective product/part back to the manufacturer. The manufacturer then assesses the product/part in question. If the manufacturer deems the claim to be justified, the product or part is repaired and/or replaced. The costs for returning the product/part to the dealer are to be borne by the dealer;

- whether the dealer should order a new product/part from the manufacturer. The dealer then receives an invoice detailing the shipping costs involved. The dealer arranges and pays for the defective product/part to be sent to the manufacturer. Once the manufacturer has received the defective product/part, it is assessed. If the manufacturer deems the warranty claim to be justified, the dealer receives a credit note for the new product/part ordered and the shipping costs involved.

If the warranty claim is deemed to be unjustified, the dealer is informed and the manufacturer makes an offer for the costs of replacement parts and/or provides an indication of the cost of repair. Once the dealer agrees to this, the product/part is repaired and/or replaced at the dealer's expense and returned at the dealer's expense. The dealer can also opt to have the product/part returned without repair at the dealer's own expense.

2017-05

Sango is a product manufactured by:

DIETZ-Power B.V.
Vlamovenweg 12
5708 JV Helmond
The Netherlands
+31 492 792 196
info@DIETZ-Power.com
www.DIETZ-Power.com