

CANEO_B/_XL // CANEO_S/_E/_L

Standard and lightweight wheelchair
User manual Version 2.0



CANEO_B



CANEO_XL



CANEO_S



CANEO_E



CANEO_L

Record of product identification data

We recommend that you write down your product identification data below (found on product label), so that you have these on hand should you require any further information about your product. (see chapter product labelling)*

TYP Type / model:	
REF Item No. / REF:	
SN Serial number:	
 Date of manufacture:	
Other information/notes:	

*The identification data on your product label may differ on custom-made devices.

Thank you for purchasing a CANEO wheelchair from DIETZ

Read these operating instructions carefully before starting to use your new TOMTAR MR-S / MR-LG. They contain important safety instructions and valuable tips on correctly using the wheelchair.

They also contain information concerning operational safety, road safety and the best possible value retention of your wheelchair.

If you have any questions or require additional information, please contact the specialist retailer which supplied the wheelchair to you.

You can always find the latest version of the user manual and information on your product on our homepage. For information or queries

concerning product safety and on recalls, please contact DIETZ in writing or by telephone. You will find our contact information on the back of these operating instructions.

For reasons of better readability, the simultaneous use of the language forms masculine, feminine and diverse (m/f/d) is dispensed with in the following and the generic masculine is used. All personal designations apply equally to all genders.



HINWEIS

A large-print version of the operating instructions is available for visually impaired persons at **www.dietz-group.de** in PDF format.

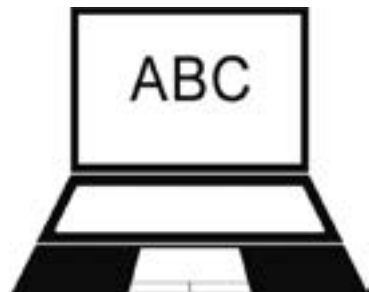

01 Important information

Intended Purpose	6
Indication	7
Contraindications	7
Symbols	7

02 Product Description

Scope of delivery	8
Accessories (optional)	8
Structure of the CANEO_S	9
Structure of the CANEO_E	10
Structure of the CANEO_L	11
Structure of the CANEO_B	12
Structure of the CANEO_XL	13

03 Setting up the wheelchair

Preparing the wheelchair for use	14
3.1 Folding/unfolding the wheelchair	15
3.2 Backrest upholstery	16
3.3 Leg rests	16
3.4 Foot plates	17
3.6 Lower leg length	18
3.7 Seat depth	18
3.8 Removing and attaching rear wheels	19

04 Using the wheelchair

Using the Wheelchair	20
4.1 Getting in and out of your wheelchair	20
4.2 Swivelling the sideguards back	22
4.3 Folding the foot plates up	22
4.4 Swivelling away and detaching the leg rests	23
4.5 Angle-adjustable foot plates	23
4.6 Propelling and slowing down the wheelchair with the push rims	24
4.7 Driving on gradients and uneven ground	25
4.8 Loading the wheelchair	25
4.8 Parking the wheelchair with the parking brake	26
4.9 Braking by an attendant (optional)	26
4.11 Tipping aid	27
4.12 Transport	28
Transport of the wheelchair without user	28
Wheelchair as a car seat	29
Attaching the wheelchair restraint systems	30
Wheelchair occupant restraint system	31

05 Individual adjustments	
Important information on adjustments	32
Tools	32
5.1 Parking brake	33
5.2 Drum brake (optional)	34
5.3 Backrest/adjustable back	34
5.4 Armrest height	35
5.5 Armrest positioning (desk/long)	36
5.6 Seat height adjustment	36
5.7 Seat angle adjustment	38
5.8 Wheelbase extension	39
5.9 Pushing handle	39
5.10 Anti-tip wheels (optional)	40
5.11 Safety belt (optional)	40
5.12 Amputee support (optional)	41
5.13 Brake lever extension (optional)	42
5.14 Angle-adjustable leg rest (optional)	43
5.15 Therapy tray (optional)	44
5.16 Accessories and add-ons from external suppliers	45

06 Technical data	
Wheelchair dimensions	46
Technical specifications	47
Materials	49
Further information	50
07 Safety instructions	
Safety information & driving restrictions	51
08 Instructions for general use	
Servicing/maintenance	53
Maintenance schedule	54
Troubleshooting	56
Cleaning	57
Disinfection	57
Forwarding / reusing	58
Storage	58
Disposal	58
Product labelling	59
09 Manufacturer's declarations	
Warranty	60
Lifetime	60
Liability	60

INTENDED PURPOSE

The CANEO wheelchair is only intended for the personal transportation and the transportation of others and can be used indoors and outdoors. Depending on the model and size, it is designed for a different maximum load, which you can check on the label.

SEAT WIDTH:	36	39-42	45	48-51	56-60
CANEO_S	125 kg		130 kg		
CANEO_E		125 kg		130 kg	
CANEO_L			150 kg		
CANEO_B		130 kg		140 kg	
CANEO_XL					170 kg / 200 kg

Persons who use the wheelchair independently must be physically and mentally capable of moving and braking the wheelchair. The user must have sufficiently good eyesight to use the wheelchair in public spaces and to use public highways.

If the wheelchair is moved by an accompanying person, the accompanying person must be physically capable of pushing and braking the occupied wheelchair.

The wheelchair is not suitable for children. The wheelchair shall not be used for the transport of more than one person or of cargo.

The intended purpose may differ for products which were manufactured as custom-made device and which have been labelled as such. In this case, please refer to the documentation supplied with the product.

INDICATION

This wheelchair provides assistance for persons who are unable to walk or who have a severe walking impediment due to

- ▼ Paralysis
- ▼ Loss of limbs
- ▼ Limb defect/deformation
- ▼ Joint contracture/joint damage (not on both arms)
- ▼ Other diseases.

CONTRAINDICATIONS

Use of the wheelchair is unsuitable in the case of

- ▼ False sensations
- ▼ Severe disequilibrium
- ▼ Loss of limbs on both arms
- ▼ Joint contracture/joint damage on both arms
- ▼ Inability to sit
- ▼ Impaired or inadequate vision.

SYMBOLS

These symbols indicate passages of text that are helpful for using and operating the product in every day life.



WARNING

It is mandatory to observe and comply with warnings.

They inform you of circumstances that could result in injury and/or damage to the wheelchair or surroundings if the warnings are not observed._____



NOTE

Tips and advice to simplify using the functions. _____

SCOPE OF DELIVERY

The CANEO_S wheelchair is packed in a cardboard box. Please keep the packaging if possible; it can subsequently be used to store the wheelchair if necessary.

On receipt of the wheelchair, please immediately check to make sure that the contents are complete and undamaged. The contents consist of:

- ▼ 1 set of cardboard box and packaging
- ▼ 1 pre-assembled wheelchair
- ▼ 1 pair of leg rests (CANEO_XL incl. footboard)
- ▼ User manual
- ▼ 4 Armrest height adapters 20mm (CANEO_E)
- ▼ Accessories (if selected)

ACCESSORIES (OPTIONAL)

Wheelchair accessories available from the manufacturer:

- ▼ Amputee support(s)
- ▼ Anti-tipping supports
- ▼ Safety belt
- ▼ Brake lever extension
- ▼ Height-adjustable side panel
- ▼ Therapy tray
- * Angle-adjustable leg rests

STRUCTURE OF THE CANEO_S

Basic components

- Corrosion resistant aluminium frame
- Tipping stability 10°
- Backrest angle 3°, Seat plane angle 3°
- Adjustable backrest Velcro
- Armrests adjustable in desk and long version, height adjustable
- Side panels can be swivelled back
- The armrests can be adjusted in 15 mm steps from 420 mm to 510 mm
- Leg rests can be swiveled to the side / removeable
- Foot plates height and angle-adjustable with heel strap
- Parking brake/Drum brake depending on the version
- Rear wheel PU 24", incl. quick-release axle, front wheel PU 7"
- Height-adjustable handles

Lightweight folding wheel-chair, comprehensive standards



fig.1

STRUCTURE OF THE CANEO_E

Basic components

- Corrosion resistant aluminium frame
- Tipping stability 10°
- Backrest angle 3°, Seat plane angle 3°
- Armrests adjustable in desk and long version
- Side panels can be swivelled back, height-adjustable
- The armrests can be adjusted in 15 mm steps from 420 mm to 510 mm
- Leg rests can be swiveled to the side / removeable
- Foot plates height and angle-adjustable with heel strap
- Parking brake/Drum brake depending on the version
- Rear wheel PU 24", incl. quick-release axle, front wheel PU 7"

Lightweight wheelchair



fig.2

STRUCTURE OF THE CANEO_L

Basic components

- Corrosion resistant aluminium frame
- Tipping stability 10°
- Backrest angle 3°, Seat plane angle 3°
- Adjustable backrest Velcro
- Armrests adjustable in desk and long version, height adjustable
- Side panels can be swivelled back
- The armrests can be adjusted in 15 mm steps from 420 mm to 510 mm
- Leg rests can be swiveled to the side / removeable
- Foot plates height and angle-adjustable with heel strap
- Parking brake/Drum brake depending on the version
- Rear wheel PU 24", incl. quick-release axle, front wheel PU 7"

Wheelchair for tall people
over 1.80 m tall

EN



fig.3

STRUCTURE OF THE CANEO_B

Basic components

Standard Steel Model

- Tipping stability 10°
- Backrest angle 3°, Seat plane angle 3°
- Armrests adjustable in desk and long version
- Side panels can be swivelled back
- The armrests can be adjusted in 15 mm steps from 420 mm to 510 mm
- Leg rests can be swiveled to the side / removeable
- Foot plates height and angle-adjustable, with heel strap
- Parking brake/Drum brake depending on the version
- Rear wheel PU 24", incl. quick-release axle, front wheel PU 7"



fig.4

STRUCTURE OF THE CANEO_XL

Basic components

- Tipping stability 10°
- Backrest angle 3°, Seat plane angle 3°
- Adjustable backrest Velcro
- Rearward swivelling reinforced side panels
- Armrests adjustable in desk and long version
- The armrests can be adjusted in 15 mm steps from 420 mm to 510 mm
- Leg rests can be swiveled to the side / removeable
- Height-adjustable foot plates, with separate aluminium foot plate & calf strap
- Reinforced rear wheel connection
- Parking brake/Drum brake depending on the version
- Rear wheel PU 24", incl. quick-release axle, front wheel PU 7"

Folding wheelchair, reinforced design for user weight 170-200 kg

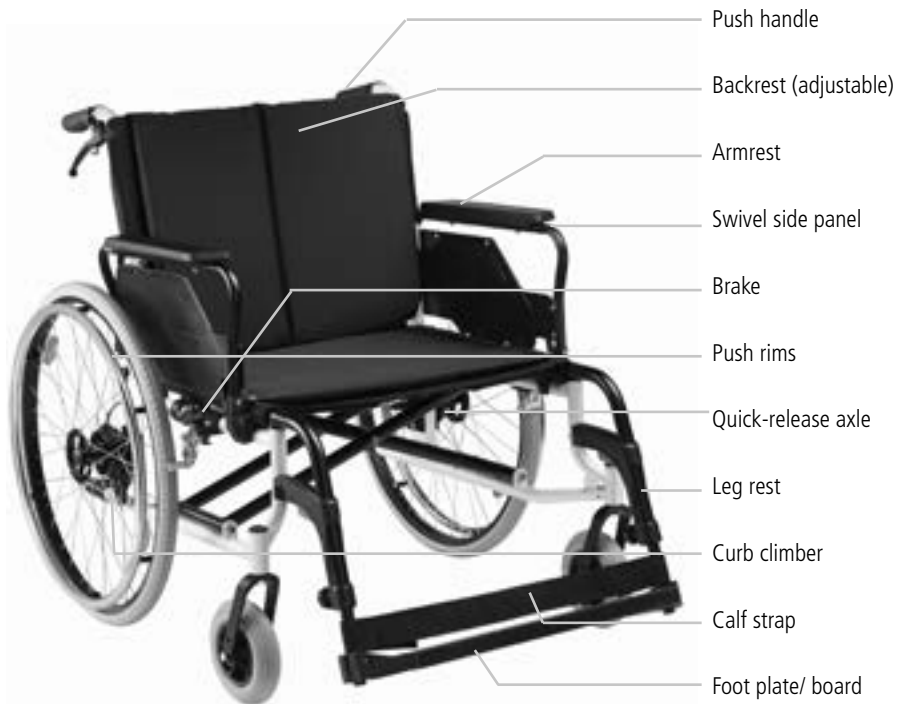

fig.5

PREPARING THE WHEELCHAIR FOR USE

The wheelchair is fully assembled at the factory. To get started you simply have to unfold the wheelchair and click the leg rests into place. In this following chapter you can find some information about how to set up and use your wheelchair. You can find information about simple settings and adjustments that can be done without any tools.

Explanations of more complex adjustments such as seat height, angle etc. can be found in chapter »05 Individual adjustments«.



NOTE

The initial set-up should be carried out by trained personnel of the medical supplies dealer. _____



WARNING

Risk of trapping: There is a risk of trapping on moving parts. In proximity of moving parts extra caution is required.

When folding and unfolding your wheelchair, pay attention to your fingers and only grip the parts as seen in the illustrations. _____

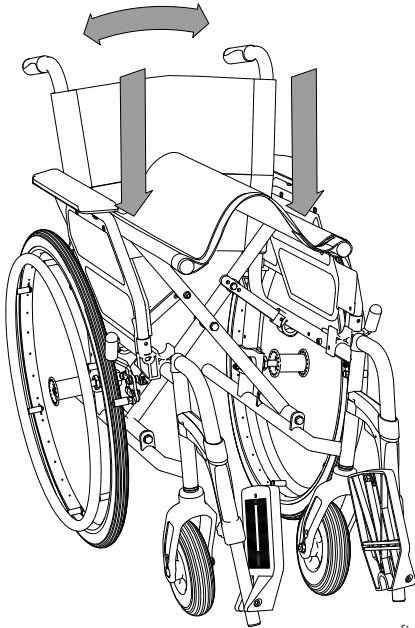

fig.6

3.1 Folding/unfolding the wheelchair

Press the left and right seat tube down simultaneously with flat hands. The wheelchair will now unfold itself. (Fig. 6).

When the wheelchair is completely unfolded, please check whether both seat tubes are correctly located in the slots provided.

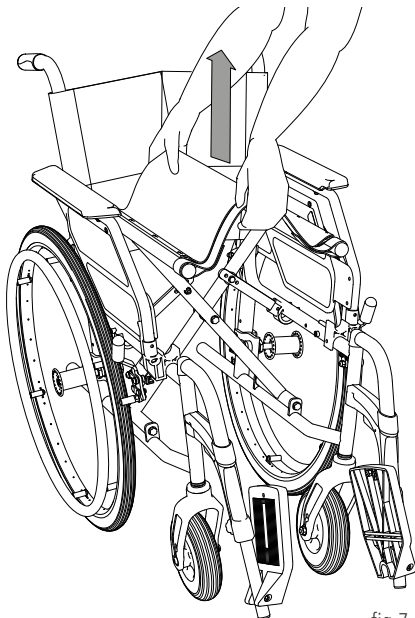

fig.7

To fold the wheelchair, loosen the flap of the backrest (see Chapter 3.2, Fig. 8) under the seat and then pull the cover upwards in the middle of the seat (Fig. 7).

3.2 Backrest upholstery

Pull the flap (Fig. 8) of the seat back cover under the seat and fasten it, this closes the gap between the backrest and seat.

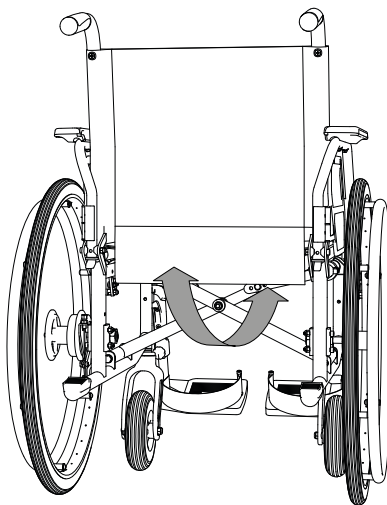

fig.8

3.3 Leg rests

1. Insert the leg rest into the guide on the wheelchair from above (1, Fig. 9). When doing so, the leg rest must be angled outwards.
2. Swivel the leg rest forwards (2, Fig. 9). You must hear and feel the leg rest engage.
3. Check that the leg rest is securely locked in place.

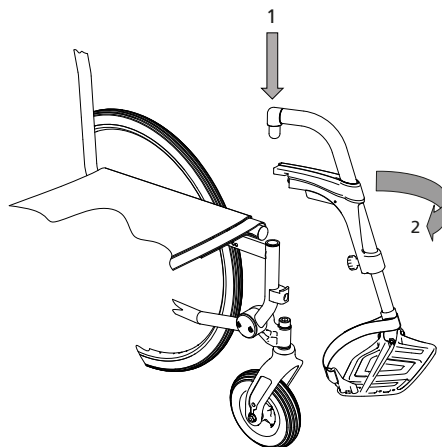

fig.9

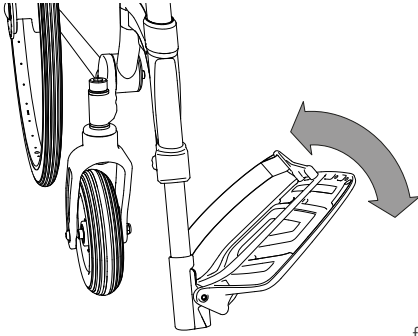

fig.10

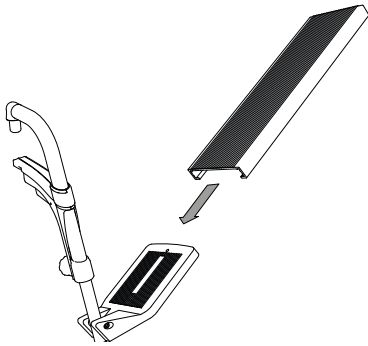

fig.11

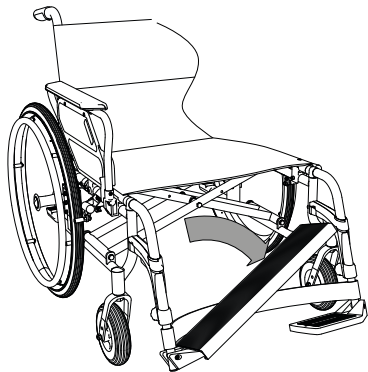

fig.12

3.4 Foot plates

CANEO_S_E_L_B

The foot plates are each equipped with a heel strap and are folded down after the leg supports have been attached. (Fig. 10).

CANEO_XL

The CANEO_XL is delivered with foot plates, its foot board and a calf strap.

Place the footboard on one of the two footplates (Fig. 11) and fold it down until it rests securely on the other footplate (Fig. 12). Then fasten the calf strap.



WARNING

Risk of trapping: There is a risk of trapping on moving parts. In proximity of moving parts extra caution is required.

3.6 Lower leg length

The setting is correct when your thighs are horizontal with the feet placed on the foot plates.

1. To do this, release the threaded connection one quarter of a turn and pull the locking mechanism backwards. (1, Fig. 13).
2. Move the foot plate into a position that is comfortable for you and release the locking mechanism again. The mechanism automatically locks in the next position. (2, Fig. 13).
3. Then tighten the threaded connection securely again.

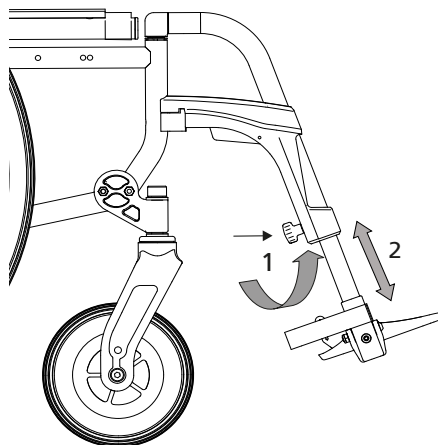

fig.13

3.7 Seat depth

The wheelchair is always delivered with the maximum possible seat depth. To reduce the seat depth, first remove the leg supports. Next, open the Velcro straps on the right and left of the seat frame. (Fig. 14).

Secure the Velcro straps to the extension so that they are no longer wrapped around the frame. Fold the extension beneath the seat and fasten the Velcro straps to secure it there. (Fig. 15).

Carry the procedure out in the opposite sequence to increase the seat depth.

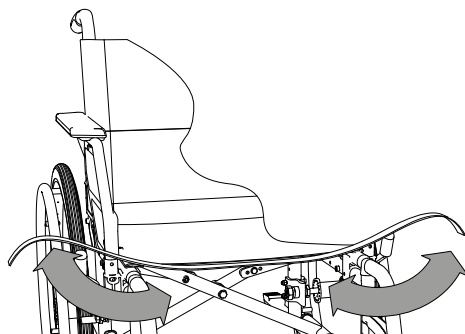

fig.14

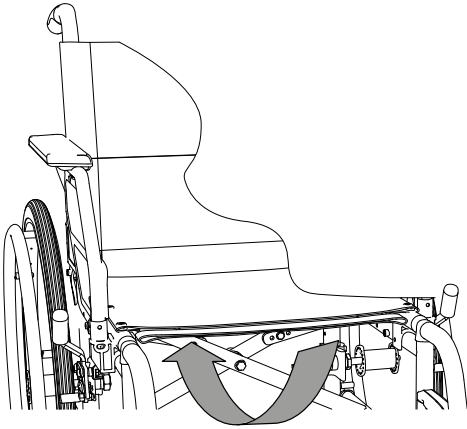

fig.15

3.8 Removing and attaching rear wheels

In some situations it is helpful to remove the rear wheels. (Fig. 16).

Press the button on the quick-release axle and hold the hub with four fingers. Then pull the rear wheel out of the axle mounting.

To connect the rear wheels, press the quick-release axle button with your thumb again. Now insert the axle into the axle mounting; the quick-release axle will engage automatically.



NOTE

Push the quick-release button while engaging the wheels. The axle/wheel will engage a lot easier. _____



WARNING

Risk of injury: After connecting the wheels make sure that the quick-release axles are engaged properly. _____

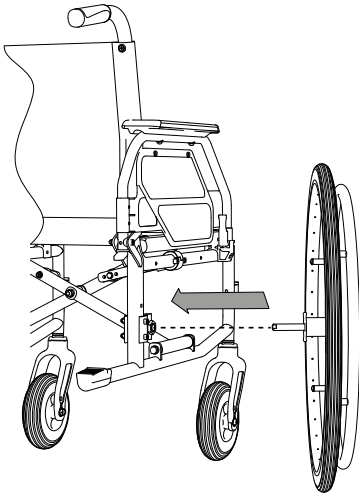

fig.16

USING THE WHEELCHAIR

4.1 Getting in and out of your wheelchair

Different handicaps allow more or less manoeuvrability.

To get in and out of your wheelchair easily and safely, the following tips can be helpful.



NOTE

Place the wheelchair backwards against a stable wall (Fig. 17). This ensures that the wheelchair will not roll away on smooth surfaces. —

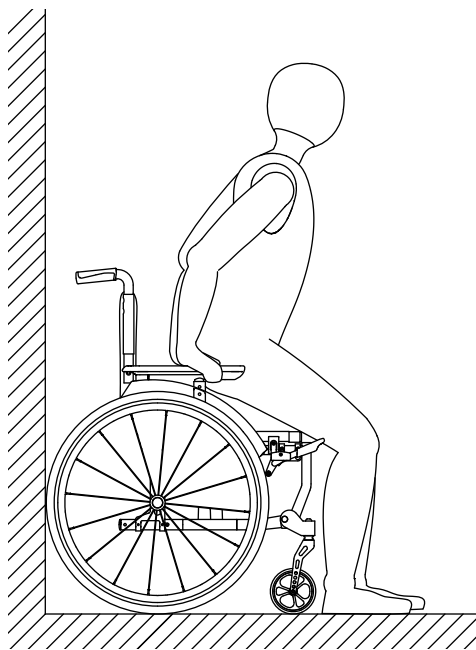

fig.17



WARNING

Do not stand on the foot plates or footboard while getting up or sitting down. They are not intended to bear the full weight of one person.



NOTE

Swivel up the side panel if transferring sideways (see chapter 4.2). _____

Getting into your wheelchair

1. Take off the leg rests (see chapter 4.4).
2. If possible, place the wheelchair's rear wheels against a solid wall.
3. Apply both parking brakes.
4. Stand as close as possible to the wheelchair. Turn around, then carefully move backwards until your legs touch the edge of the seat.
5. Now grab the armrest with your hands.
6. You can now sit down slowly and safely.
7. Then swivel both the leg rests back to the front in the direction of travel. Listen and feel for the click to ensure that the leg rests are correctly engaged.
8. Finally, fold both the foot plates downwards using your feet and place your feet on the foot plates (see chapter 3.4).

Getting out of your wheelchair

Carry the procedure out in the opposite sequence.

4.2 Swivelling the sideguards back

To swivel up, press the locking lever and pull the sideguard upwards.

The arm rest engages automatically on swivelling back.

This engagement is clearly audible. (Fig. 18).

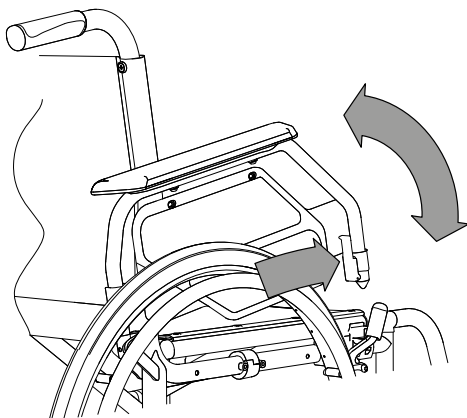

fig.18

4.3 Folding the foot plates up

Fold the foot plates up to make entering and exiting easier. (Fig. 19).

The foot plates must be folded up to save space when folding the wheelchair together.

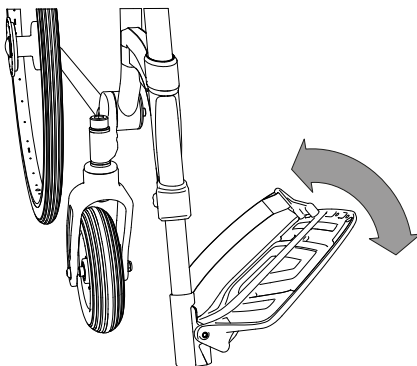

fig.19

4.4 Swivelling away and detaching the leg rests

To remove the leg rests, first fold the foot plates up. (see 4.3)

1. Actuate the locking mechanism in red/orange (1, Fig.20) and swing the leg rest outwards.
2. Now you can pull upwards on the leg rests. (2, Fig. 20).

Carry the procedure out in the opposite sequence during assembly. When the leg rest is swivelled forwards, it audibly clicks into place.

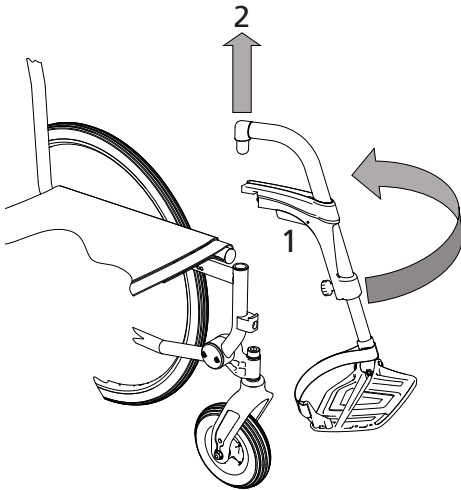

fig.20

4.5 Angle-adjustable foot plates

The CANEO_S / _E / _L are equipped with angle-adjustable foot plates as standard. To change the angle, first

1. loosen the screw (1, Fig.21) a few turns. Now you can set the desired foot plate angle (2, Fig. 21).
2. Then tighten the screws (1) again.

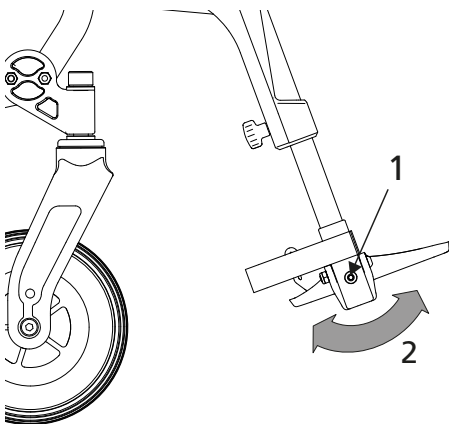

fig.21

4.6 Propelling and slowing down the wheelchair with the push rims

The wheelchair is pushed and slowed down using the push rims. Grip the push rims with your hands with your thumbs pointing forwards on the push rims (see Fig. 22).

To propel the wheelchair forwards: Push both wheels forwards evenly.

To propel the wheelchair backwards: Push both wheels backwards evenly.

To stop the wheelchair: Close your hands around the push rims and gradually increase the pressure of your grip.

To steer to one side: Slow the wheel on the side to which you wish to turn.

To turn the wheelchair on the spot: Push one wheel forwards and the other wheel backwards at the same time.

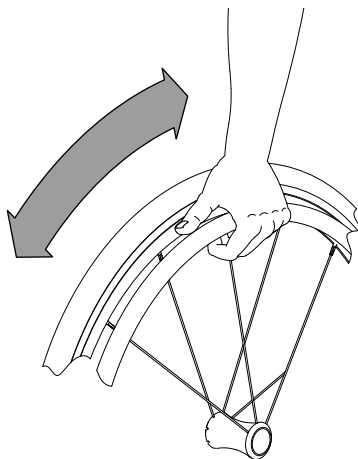

fig.22



WARNING

Risk of trapping: between the tyre and side-guard/armrest!

Risk of injury: During hard braking manoeuvres the push rims can become quite hot. Wear suitable gloves.

Risk of injury: Ensure that your thumbs do not touch the tyre casing of the wheel whilst the wheelchair is in motion. _____

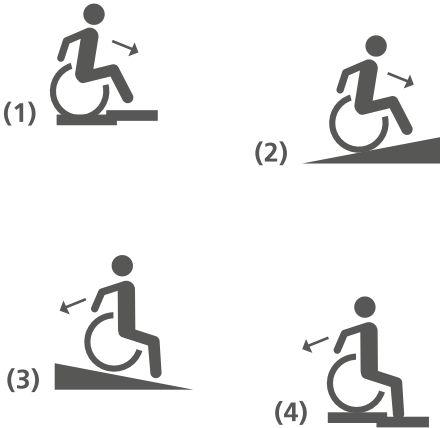

fig.23

4.7 Driving on gradients and uneven ground

Potholes and uneven ground can cause the wheelchair to tip over when driving over ramps, slopes, gradients and kerbs.

Lean your body forwards when driving upwards over a step or slope. (1 & 2, Fig. 23)

Lean your upper body further backwards when driving down slopes and steps. (3 & 4, Fig.23)



WARNING

Risk of trapping: Always drive up or down slopes/gradients in a straight line and at a reduced speed. Do not drive over slopes or gradients obliquely as this increases the risk of tipping over.

Risk of injury: If you brake the wheelchair for a long time using the handrims, e.g. when driving downhill, a lot of frictional heat is generated on the handrims. Wear suitable gloves. _____

4.8 Loading the wheelchair

Additional loads (backpacks or similar objects) up to max. 5 kg can be hung from the push handles as long as the max. user weight is not exceeded.



WARNING

Hanging loads on the wheelchair increases the risk of it tipping over backwards.

That is why DIETZ recommends using anti-tipping supports. _____

4.8 Parking brake

The wheelchair has one parking brake on either side. They can be used to park the wheelchair safely.

1. Press the brake lever forwards so that the brake blocks the wheel (1, Fig. 24).
2. Press the brake lever further forwards until you feel it engage (2, Fig. 25).

To release the parking brake: Pull the brake lever backwards.



WARNING

Do not use the parking brakes to stop the wheelchair during motion as this may cause the wheels to block. Due to the immediate locking of the wheels, you may no longer be able to control the direction of travel.



NOTE

Use both parking brakes when parking the wheelchair. This ensures that the braking force is evenly distributed on both rear wheels.

4.9 Braking by an attendant (optional)

While moving, slow down the wheelchair by pulling both levers upwards. To park the chair you can lock the brake levers. To do this, pull up the lever and subsequently pull up the small locking lever. (Fig. 26).

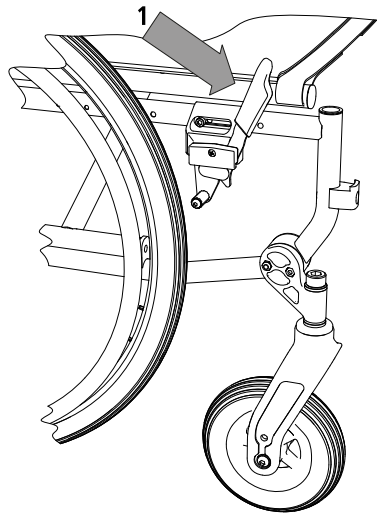

fig.24

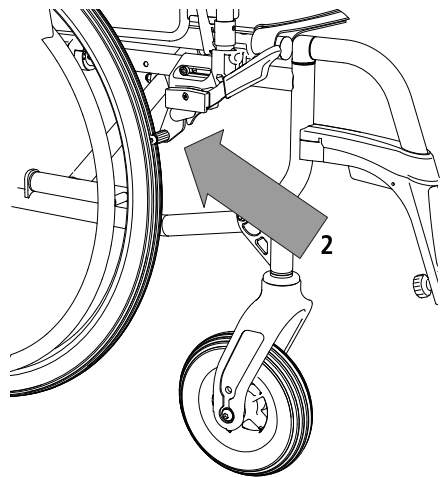

fig.25

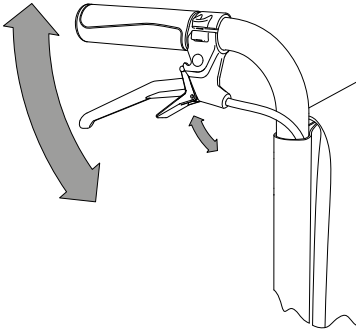

fig.26

The locking lever will then engage automatically. To release the brake simply pull the brake lever upwards and the locking lever will release automatically.

The accompanying person can use the optional drum brake as a service and parking brake. This is particularly advantageous when moving on slopes. Movement can then be reduced by applying the brake levers more or less strongly as required. In addition, the drum brake can also be used as a parking brake.



WARNING

In models without an optional drum brake, the accompanying person must be physically and mentally able to stop the wheelchair using his own strength. The locking brake is then available as a parking brake.



NOTE

Always use the left and right brake simultaneously. Using only one side will make the chair very hard to manoeuvre.

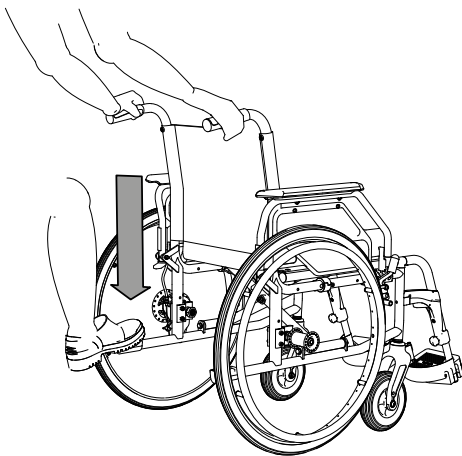

fig.27

4.11 Tipping aid

The tipping aids enable the accompanying person to tilt the wheelchair and therefore move it over obstacles more easily. Place your foot onto the back of the frame tube and maintain balance using the pushing handle. (Fig. 27). Optionally, instead of a curb climber you can fit anti-tipping supports. These can also be used as a curb climber if the anti-tipping wheels have been set to the highest position beforehand. (see chapter 5.10)

4.12 Transport

Transport of the wheelchair without user

To transport the wheelchair in a car, airplane, train or simply to create space, the wheelchair can be folded and separated into portable elements without any tools. It then only takes up a very small amount of room and is easy to store. Please check the individual transportation requirements of the airline-/railway company regarding the packing/dimensions for the wheelchair transportation.

CANEO_S folded W/L/H in mm = 310 / 780* / 920

CANEO_E folded W/L/H in mm = 310 / 780* / 920

CANEO_L folded W/L/H in mm = 310 / 850* / 1005

CANEO_B folded W/L/H in mm = 310 / 780* / 920

CANEO_XL folded W/L/H in mm = 340 / 850* / 950

*Length folded without leg rests

Please pay attention to the following points when transporting the wheelchair without a user:

1. Fold the wheelchair for transport. (Chapter 3.1)
2. Carry the folded wheelchair by holding the front of the side frame and the push handles.
3. Components that can easily be detached from the wheelchair when stowed should be removed and stored in a suitable, safe place. (such as table, walkers, cushions, etc.)
4. Lash the unoccupied wheelchair securely in place.
5. The wheelchair must not be loaded during transport.
6. The wheelchair can be transported upright with and without rear wheels. (Chapter 4.10 - Removing and attaching rear wheels)
7. The wheels must be kept attached to the wheelchair if it is transported lying on its side.
8. Activate the locking brakes when transporting the wheelchair with rear wheels.



NOTE

To set up the wheelchair, follow the operating instructions in chapter **»03 Setting up the wheelchair«**.

7176-19	tested with 4-point strap tiedown system	tested with AMF power node system
CANEO_S	Crash tested	Crash tested
CANEO_E	Crash tested	Crash tested
CANEO_L	-	-
CANEO_B	-	Crash tested
CANEO_XL	-	Crash tested



ISO 7176-19 certification badge



fig.28

Wheelchair as a car seat

Wheelchairs are not designed for use as passenger seats in vehicles and do not provide the same level of safety as regular vehicle passenger seats, regardless of how well they are fastened and secured inside the vehicle. DIETZ therefore recommends to seat wheelchair users on regular vehicle seats whenever possible. The CANEO_S is ISO 7176-19-compliant and therefore suitable for use as a passenger seat in vehicles (see table).

All wheelchairs that have been crash-tested are marked accordingly. (see Fig. 28). It has been tested using a H3 50% dummy (78 kg) and a head restraint (ISO 10542).

Passenger cars designed for transporting wheelchair users while seated in a wheelchair have to have a wheelchair space in accordance with the German Road Traffic Licensing Regulation (StVZO). All wheelchair spaces in a vehicle have to be provided with a wheelchair and wheelchair occupant restraint system capable of restraining the wheelchair and its occupant. The vehicle owner and driver must provide vehicle-integrated restraint systems compliant with either ISO 10542 or DIN 75078-2 (power node system) and make sure they are used in accordance with the regulations.



WARNING

Risk of injury: Always ask the carrier whether the respective vehicle is designed, insured and equipped to carry a person in a wheelchair. Failure to observe these instructions can result in severe bodily injury and danger to life! _____

Attaching the wheelchair restraint systems

To secure the CANEO_S and CANEO_E, only a 4-point wheelchair restraint system with tension belts certified according to ISO 10542, which is designed for the total weight of the wheelchair, is used without a tie-down. The 4 tie down strap attachment points on the wheelchair are marked with a hook symbol (see examples (A) and (B) Fig. 29). When securing the CANEO, the straps must be attached to all 4 attachment points and the wheelchair placed such that the occupant is facing the direction of travel in compliance with ISO 10542 (WTORS). Under no circumstances must the wheelchair be strapped in place using other attachment points (e.g. anti-tip bar, armrests). No modifications must be made to the transport anchor points of the wheelchair without the permission of DIETZ.

The wheelchair restraint system must be installed in the vehicle in line with the manufacturer's assembly instructions.

The CANEO_S_E_B_XL was also tested with the AMF-Bruns power node system (DIN 75078-2 / ISO 10542). Please follow the manufacturer's installation instructions (www.amf-bruns-behindertenfahrzeuge.de) when securing the restraint system with a power node system. The restraint system must be fitted by qualified and expert personnel.

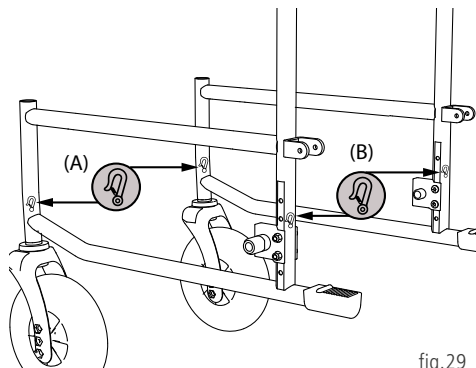

fig.29

(A) Front attachment point on the wheelchair

(B) Rear attachment point on the wheelchair



WARNING

The CANEO has been tested in the direction of travel in compliance with ISO 7176-19 / ISO 10542. For safety reasons, the CANEO must not be used / secured in such a way that it would face backwards or sideways when occupied.____



WARNING

The geometry of the attachment points (or of the fastening system) must be adjusted with just as much precision as the wheelchair user's safety belts to ensure that a wheelchair user seated in a wheelchair inside a vehicle will be safely transported. Non-observance of these requirements can put the wheelchair user's life at risk in the event of an accident.



(C) Correct attachment of the safety belts fig.30

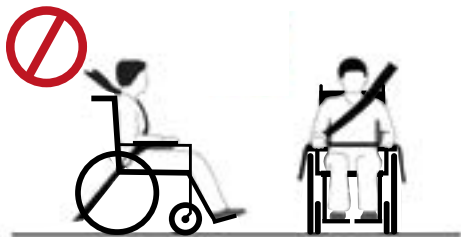

(D) Wrong way to attach the safety belts fig.31

Wheelchair occupant restraint system

The wheelchair restraint system must be secured first. Once secure, the wheelchair occupant must be secured with a corresponding ISO 10542 compliant restraint system.

When doing so, the following must always be ensured:

- ▼ Fasten the shoulder and lap belt. Both of these belts must be fastened quite tightly, but not so tight as to cause discomfort to the wheelchair user and must not be twisted.
- ▼ We strongly recommend using a head restraint suitable for use in a vehicle when transporting wheelchair users.
- ▼ The lap belt must run at an angle of 30° to max. 75° from the horizontal but under no circumstances greater than 75° (C, Fig. 30).
- ▼ Safety belts must not be routed over components of the wheelchair, such as armrests or wheels, which would hold it away from the body. (D, Fig. 31).
- ▼ Only products that are certified according to ISO 7176-19 / ISO 10542 or DIN 75078-2 (tie-downs) and have been identified accordingly by the manufacturer may be used as a restraint system. The wheelchair's parking brakes must be fully engaged throughout the drive.

- ▼ Components such as, e.g. activity trays, cushions or walking aids etc. that are easy to remove from the wheelchair must be removed before driving off. Keep them in a suitable safe place.
- ▼ Do not raise manually moveable/height-adjustable footrests when the wheelchair is being occupied during a journey and if the wheelchair has been secured with a restraint system and safety belt.
- ▼ Adjustable backrests must be moved into an upright position:
- ▼ The wheelchair user's safety during transport depends on the care with which the restraint system has been secured. The person having secured the restraint system must be trained or instructed in the use of the system.
- ▼ Wheelchairs that have been involved in an accident must be checked by a DIETZ service technician before any further use.

IMPORTANT INFORMATION ON ADJUSTMENTS

Accessories are sometimes required for the settings described below. Only original accessories from DIETZ may be used. Only then is the compliance and thus the safety of the product guaranteed.

When setting up a new user for the first time, all wheelchair adjustments must be carried out by qualified specialists so that correct positioning and safety can be guaranteed.

Tools

The following standard tools are required for the CANEO wheelchair:

Allen key sizes 4, 5 & 6

Open-end wrench AF 10, 13, 19, 26
cross tip screwdriver



WARNING

Complex adjustment tasks that can result in a risk of accident if not performed correctly must only be conducted by designated specialist staff and are labelled accordingly. "Only to be performed by specialist staff"

This particularly applies to adjusting the brakes and for settings that affect the stability of the wheelchair.

5.1 Parking brake

Only to be performed by specialist staff:

The distance between the brake pin and tyre casing must be 12–14 mm at the narrowest point when the brake is fully open. (1, Fig. 32).
Tools: Allen key size 5 mm and open-end wrench AF 10.

The brake is moved in the slot for fine adjustment. To do this, loosen the screw (2, Fig. 32). Then push the brakes into the correct position. Now retighten the screw and check the function of the brakes. When the brakes are applied, it must not be possible to push the wheelchair.

When changing the wheelbase, it is necessary to completely remove the screw (2) and mount the brake in a hole further back, as the wheel is moved 70 mm further back. Finally, the fine adjustment is carried out again via the elongated hole.

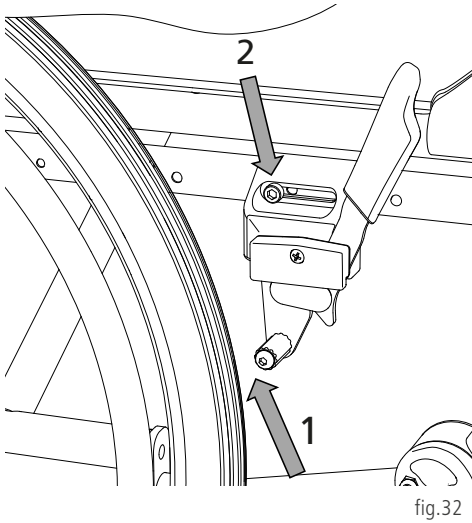

5.2 Drum brake (optional)

Only to be performed by specialist staff:

In order to achieve an optimal braking effect, the braking force is adjusted on the adjusting screw on the brake cable. The braking force is increased by loosening the adjusting screw. Loosen the lock nut and unscrew the adjusting screw until you hear grinding noises from the turning wheel. Then screw in the adjusting screw until the grinding noises stop. Once you have finished adjusting the settings, the adjusting screw is fixed by tightening the lock nut. (Fig. 33)

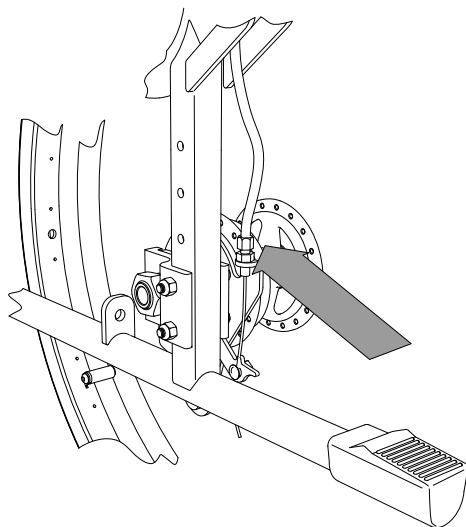

fig.33



WARNING

Ensure that the drum brakes are evenly adjusted on both sides of the wheelchair. _____

5.3 Backrest/adjustable back

You can adjust your backrest surface according to your requirements. (CANE0_S_L_XL)

To do this, remove the padded backrest surface cushion and release the straps' Velcro fasteners. The straps' Velcro fasteners can then be re-fastened in the desired setting, starting with the bottom strap. Finally, fold the padded cushion over the backrest surface again. (Fig. 34)

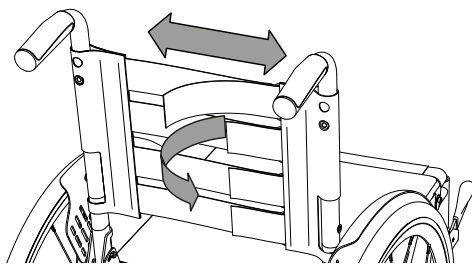

fig.34

5.4 Armrest height

The height of the armrests on the CANEO_S_L can be adjusted without tools for comfortable and fatigue-free sitting. (240/260/280 mm)
To do this, release the threaded connection (1, Fig.35) one quarter of a turn and pull the locking mechanism backwards. Then move the armrests to a position which is comfortable for you. Then release the locking mechanism again. The mechanism automatically locks in the next position. Then tighten the threaded connection securely again.

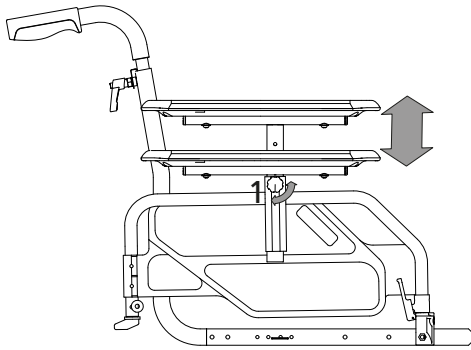

fig.35

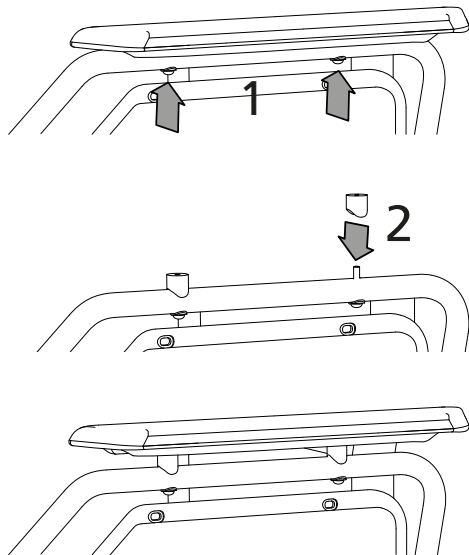

fig.36

CANEO_E

For comfortable and fatigue-free sitting, the height of the armrests on the CANEO_E can be adjusted from 220 to 240 mm using a 20 mm high spacer.

Loosen the screws that secure the armrest to the frame (1, Fig. 36). Then remove the armrest and place the side panel riser (2, Fig. 36) on the long screws. Now you can put the armrest back in. Then tighten the threaded connection securely again.

Repeat this step on the other side.

5.5 Armrest positioning (desk/long)

CANEO_S_L

The position of the arm rests can be adjusted to meet your requirements. To do this, release the threaded connection one quarter of a turn and pull the locking mechanism backwards. Now remove the left and right arm rests, interchange their positions and reinsert them. Then tighten the threaded connection securely again. (Fig. 37)

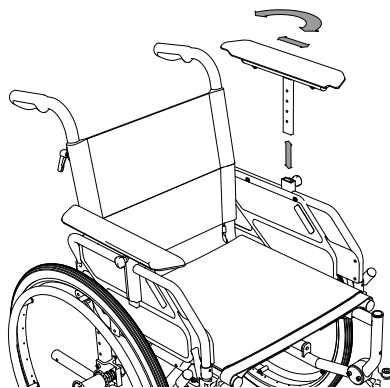

fig.37

CANEO_E_B_XL

Loosen the screws that secure the armrest to the frame. The armrests can then be moved backwards or forwards. Then reinsert the screws and tighten them. (Fig. 38)

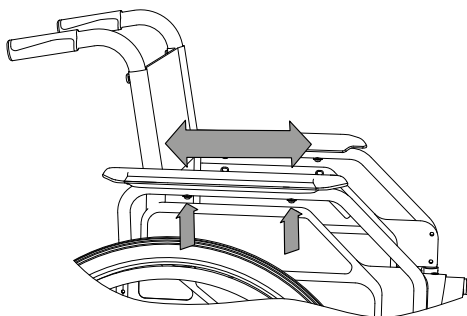

fig.38

5.6 Seat height adjustment

Only to be performed by specialist staff:

The height of the wheelchair's seat is adjusted in 4 stages of 30 mm. The setting is made via the 2 holes in the front wheel fork and the attachment of the adapter plate of the rear wheel in the different frame holes. For additional seat heights, it is also necessary to swap the left and right castor and turn them upside down. (see Fig. 39 - 41 as well as seat height table)

1. Change hole in the wheel fork (if necessary)
2. If necessary: The castor bushings are released from the frame and from the wheel fork using 3 screws each. Swap the castors on the right with the left and mount them upwards on the frame and the other wheel fork.
3. Mount the rear wheel adapter plate to the appropriate height. (Frame hole 1-5)

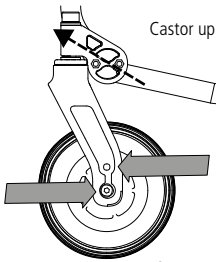

fig.39

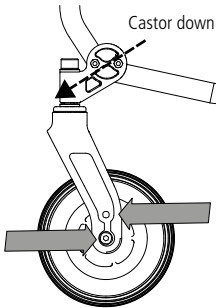

fig.40

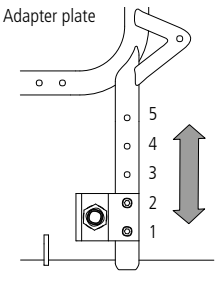

fig.41

Seat height	CANEO_S/_E	CANEO_L	CANEO_B	CANEO_XL
420 mm wheel fork castor bushing adapter plate	top hole l/r swap, to top hole 4 & 5	X	X	X
440 mm wheel fork adapter plate	X	X	X	top hole hole 2 & 3
450 mm wheel fork castor bushing adapter plate	lower hole l/r swap, to top hole 3 & 4	X	X	X
470 mm wheel fork adapter plate	X	X	X	Standard bottom hole hole 1 & 2
480 mm wheel fork castor bushing adapter plate	top hole stays in bottom hole 2 & 3	top hole l/r swap, to top hole 4 & 5	top hole ----- hole 2 & 3	X
510 mm wheel fork castor bushing adapter plate	Standard bottom hole stays in bottom hole hole 1 & 2	lower hole l/r swap, to top hole 3 & 4	Standard bottom hole ----- hole 1 & 2	X
540 mm wheel fork castor bushing adapter plate	X	Standard top hole stays in bottom hole hole 2 & 3	X	X
570 mm wheel fork castor bushing adapter plate	X	bottom hole stays in bottom hole hole 1 & 2	X	X



WARNING

A change in the height of the seat necessitates readjustment of the brakes (see chapter 5.1).

5.7 Seat angle adjustment

CANEO_S_E_L

Only to be performed by specialist staff:

Tools: Allen key 5, 6 and open-end wrench 19

This adjustment option is used only to compensate for the seat angle, which is set at the factory at 3 degrees. Make sure that the castor angle is always 90° to the floor (Fig. 43). A castor angle that deviates from 90° will always have a negative impact on the wheelchair's driving behaviour.

The angle setting of the castor can be adjusted in three steps (6°, 3° (standard), 0°) by rotating the castor inlay. Each of the set angles are shown in a window in the castor housing. (Fig. 42)

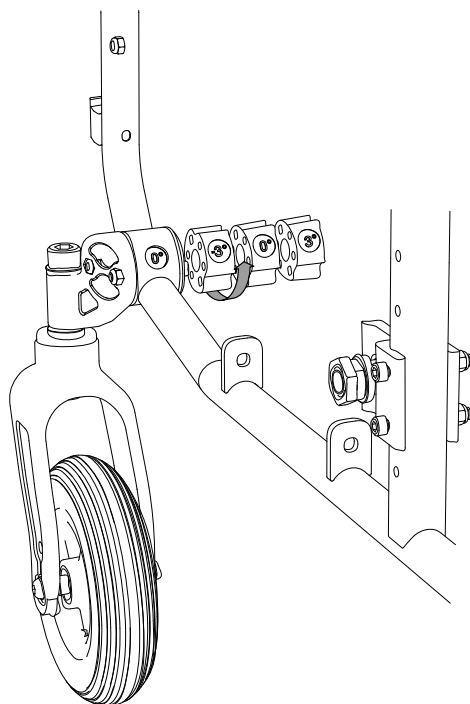

fig.42



WARNING

After setting the seat angle, check that the castor bushing is at right angles to the ground. For precise adjustment, we recommend using a 90° try square.

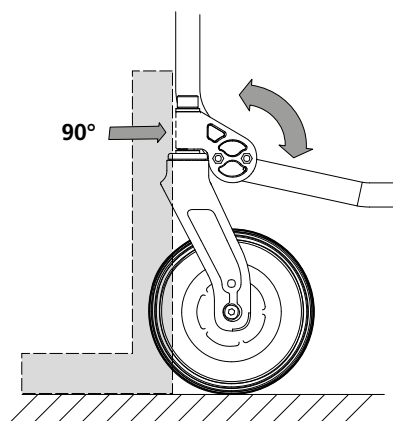

fig.43

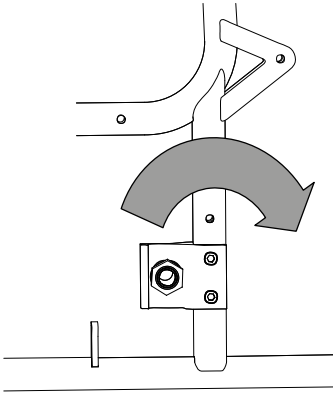

fig.44

5.8 Wheelbase extension

CANEO S_E_L_B

Only to be performed by specialist staff:

Moving the rear wheels backwards increases the distance between wheels and therefore also the stability of the wheelchair. Moving the rear wheels forwards will increase the manoeuvrability of your wheelchair but make the chair less stable.

First remove the rear wheels and secure the wheelchair so that it EN does not tip over. Then loosen and completely remove the two screws on the adapter. Now rotate the adapter by 180° vertically and attach it. Make sure that the bolts are tightened securely again. (Fig. 44)



WARNING

Altering the wheelbase means the locking brakes will have to be readjusted (see chapter 5.1).

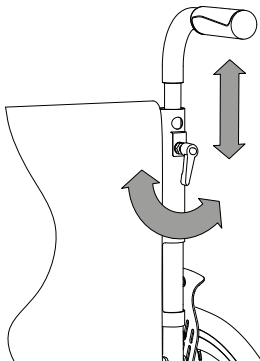

fig.45

5.9 Pushing handle

CANEO_S

The pushing handle can be easily adjusted to meet the requirements of the accompanying person.

First release the clamping levers. Then move the pushing handle to a position which is comfortable for you. Then tighten the threaded connection securely again. (Fig. 45)

5.10 Anti-tip wheels (optional)

Only to be performed by specialist staff:

The optional anti-tip wheels prevent the wheelchair from tipping backwards. In addition, they can be used to make tilting easier for an attendant.

To tilt the wheelchair the wheels can be height adjusted. To do so, pull the silver-coloured disks towards you and push the tube along the holder up or down. (Fig. 46)

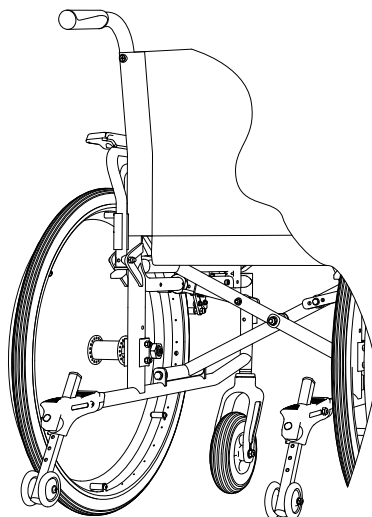

fig.46

5.11 Safety belt (optional)

Only to be performed by specialist staff:

An optional belt can be installed. This secures and stabilises the person seated in the wheelchair. It prevents the person from tipping forwards out of the wheelchair.

The seat belt is secured to the backrest tube on the left and right. Subsequent installation should be carried out in a specialist workshop. (Fig. 47 - 49)

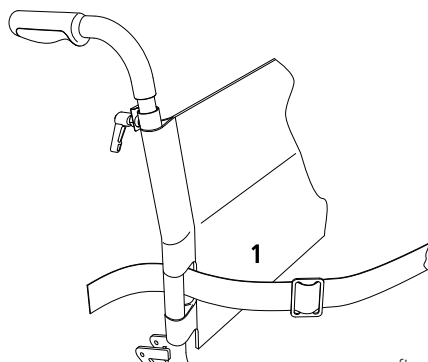

fig.47

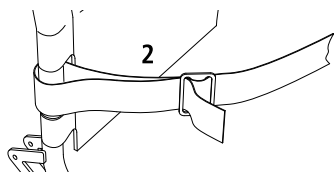

fig.48

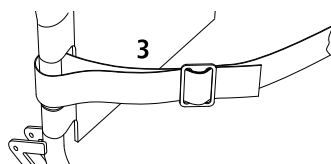

fig.49

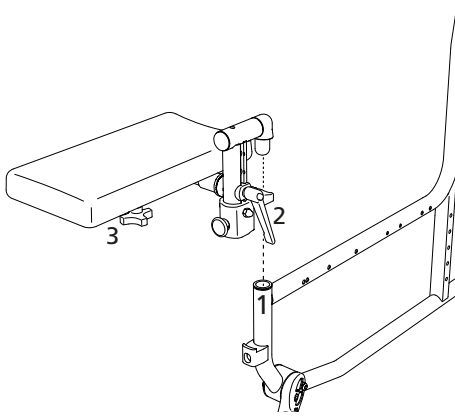

fig.50

5.12 Amputee support (optional)

1. Remove the leg rest (chapter 4.4).
2. Grasp the amputation support by the cushion and insert it from above into the frame tube (1, Fig. 50).

Adjust the angle and height:

1. Release the clamping lever counterclockwise (2, Fig. 50).
2. The amputation pad can now be adjusted to any angle and in three height settings.
3. Tighten the clamping lever in a clockwise direction.

Adjusting the height:

1. Loosen the star grip screw (3, Fig. 50).
2. The amputation pad can now be adjusted to any height.
3. Finally, tighten the screws again.

5.13 Brake lever extension (optional)

Only to be performed by specialist staff:

The brake lever extension is used to make it easier to transfer force to the brake. (Fig. 51)

Tools: Allen key size 5 and cross tip screwdriver

1. Remove the standard brake lever completely, as shown in the diagram. (1, Fig. 51).
2. Attach the brake lever extension to the chair (2, Fig. 51) in the reverse order.
3. Make sure that the brake pad is at the correct distance from the tyre surface (Chapter 5.1) and that the braking effect is even and sufficient on both sides.

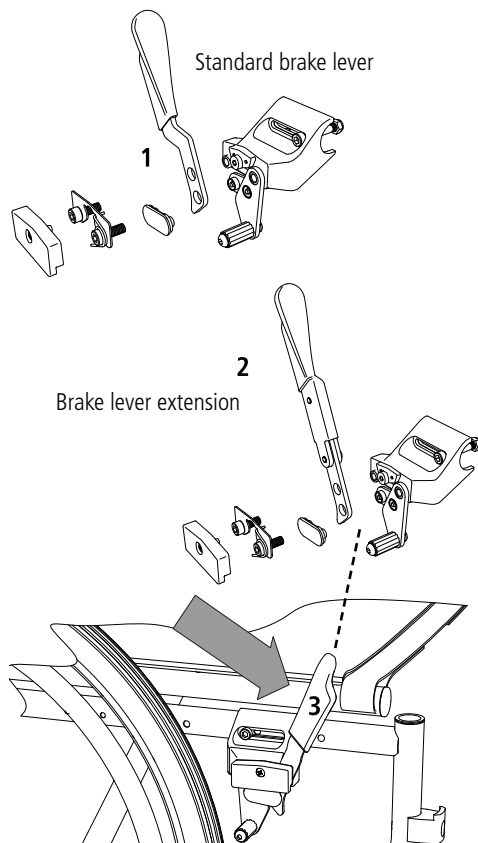

fig.51

5.14 Therapy tray (optional)

The therapy tray is mounted using a set of rails. For further information, see the assembly instructions delivered along with the therapy tray. (Fig. 52)

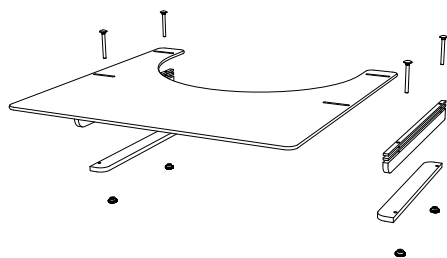

fig.52

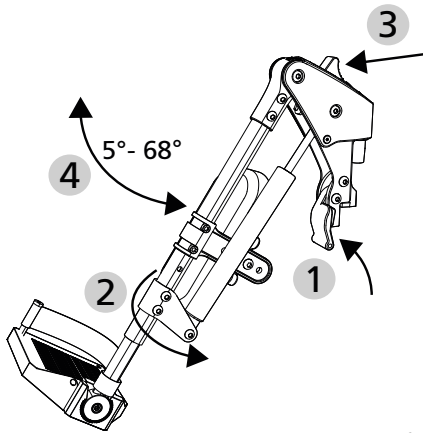

fig.53

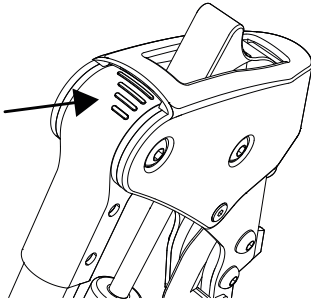

fig.54

5.15 Elevating leg rest (optional)

The calf pad have to be installed before using for the first time. Use the enclosed 5 mm Allen screw and nut and install in the third position hole on the calf pad holder (see 5, fig. 55 s. 44).

When attaching the leg rest to the wheelchair, proceed in the same way as with a standard leg rest (see the wheelchair user manual). To fold the leg rest, move the locking lever forwards whilst rotating the leg rest to the side (1/2, fig. 53).

Adjusting the angle of the leg rest 5°- 68°

1. Press the release lever for the pneumatic spring forwards (3/4, fig. 53). The knee angle falls from 68° to 5° as long as the release lever is kept pressed.
2. To set an angle, let the release lever of the pneumatic spring go at the desired position.
3. The grid lines can be used as an orientation for the set angle (fig. 54).
4. Press the release lever forwards and push the leg rest down at the same time to increase the knee angle (fig 53).



WARNING

Risk of trapping: there is a risk of trapping on moving parts (e.g. calf pad, pivot lever)

Risk of injury: do not stand on the foot plate or carry the wheelchair by the leg rests. They are not intended to bear the full weight of one person. —

Adjusting the lower leg length:

1. To adjust the length, loosen the Allen screw 4 mm (A, fig. 55) by a few rotations (1, fig. 55), but do not loosen it fully.
2. Then pull/slide the foot plate to the desired length (2, fig. 55). Pay attention to the minimum gap of 40 mm between the foot plate and the ground.
3. To lock it in place, tighten the screw (A, fig. 55) again firmly. Make sure that the screw engages in the interior carriage.

Adjusting the foot plate angle:

1. Loosen the Allen screw 5 mm (B & 3, Fig.55).
2. Pull the foot plate off on the inside.
3. Re-insert the foot plate at the desired angle (4, fig. 55).
4. Finally, fasten the foot plate in place again with the Allen screw B.

Positioning the calf pad:

1. Loosen the 2 Allen screws 5 mm on the holder to adjust the height. Following adjustment, fix the screws back into the hole pattern in 30 mm steps (1, fig. 56).
2. Loosen the Allen screw 5 mm to enable depth adjustment. Following adjustment, fix the screws back into the hole pattern in 20 mm steps (2, fig. 56).

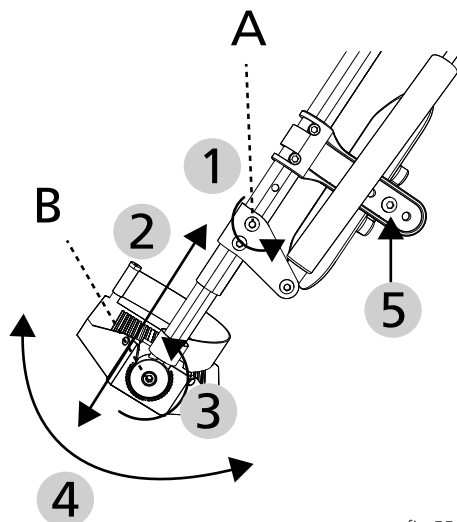

fig.55

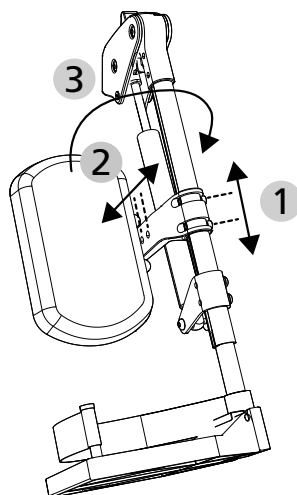

fig.56

**WARNING**

The calf pad can be swivelled outwards with the holder to relieve the calf and give the leg more room (3, fig. 56)



WARNING

The safety of the product cannot be guaranteed if attachments or accessories are used that are not sold by DIETZ.

If accessories or add-ons are added to the wheelchair, then the safety instructions in the operating instructions for the accessories or add-ons must be observed. _____

5.16 Accessories and add-ons from external suppliers

In general only original accessories from DIETZ may be used. If third-party products are installed on the wheelchair, responsibility for the safety of the product passes to the person who installs the accessories or carries out the installation.

The compliance of the combination of accessories or add-on and product is then new, and must be declared by the person who attaches it. The compliance declared by DIETZ according to MDR 2017/745, Annex II expires.

WHEELCHAIR DIMENSIONS

The dimensions given here refer to the standard configuration of the wheelchair and may vary depending on the wheelchair model and configuration.

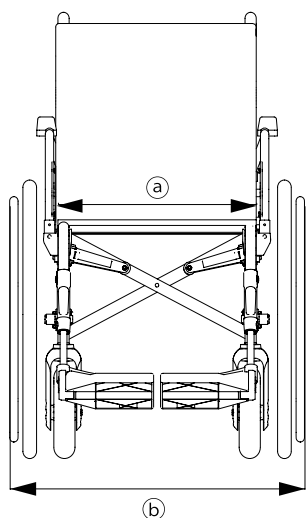

NOTE

All dimensions taken on textile parts (e.g. back upholstery) are to be understood with a tolerance of ± 10 mm.

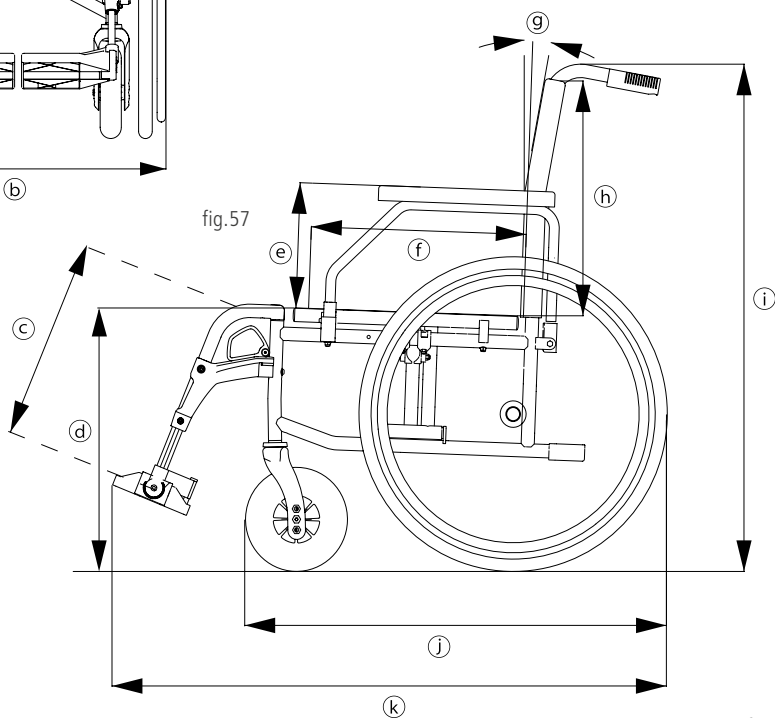

fig.58

Technical specifications			CANEO_S		CANEO_E		CANEO_L	
			Min.	Max.	Min.	Max.	Min.	Max.
k	Total length with leg rests	mm	1070	1120	1070	1120	1130	1200
j	Total length without leg rests	mm	780		780		850	
b	Total width ¹	mm	560	650	590	650	655	715
i	Total height	mm	830	920	830	920	915	1005
	Length folded	mm	780		780		850	
	Width when folded	mm	310		310		310	
i	Height folded	mm	830	920	830	920	915	1005
	Total mass ²	kg	16.6	18	15.7	16.9	18.2	18.3
	Mass of the heaviest part ³	kg	11.5	12.8	10.5	11.7	13	13.1
	Static stability downhill ⁴	°	10		10		10	
	Static stability uphill ⁴	°	10		10		10	
	Static stability sideways ⁴	°	10		10		10	
	Seat plane angle ° (adjustable)	°	3 (0 / 6)		3 (0 / 6)		3 (0 / 6)	
f	Effective seat depth (adjustable)	mm	400	440	400	440	470	510
a	Effective seat width	mm	367	517	367	517	457	517
d	Seat surface height (front edge) ⁵	mm	420	510	420	510	480	570
g	Seatback angle (with lumbar kink)	°	3 (10)		3 (10)		3 (10)	
h	Backrest height	mm	400	430	400		460	
c	Footrest to seat distance	mm	420	510	420	510	420	510
	Leg rest angle relative to seat	°	110		110		110	
e	Armrest to seat distance (adjust.)	mm	240 / 260 / 280		220	240	240 / 260 / 280	
	Armrest length from back frame	mm	330	380	330	380	330	380
	Push rim diameter	mm	530		530		530	
	Horizontal position of axle	mm	-35	35	-35	35	-35	35
	Minimum turning radius	mm	1160	1180	1160	1180	1250	1325
	Maximum user weight ⁶	kg	125	130	125	130	150	

¹ The total width of 71 cm exceeds the recommended dimension of 70 cm stipulated by DIN EN 12183.

² Wheelchair mass standard version without drum brakes

³ Wheelchair weight minus removable parts (without rear wheels and without leg rests)

⁴ The static stability indicates the wheelchair's tipping resistance on slopes and gradients.

⁵ The seat height is measured according to ISO 7176-7 at the center of the front edge of the textile seat covering.

⁶ Maximum user weight including any load. 125kg up to SB 45 | 130 kg from SB 48 (Double cross brace)

Technical specifications			CANEO_B		CANEO_XL	
			Min.	Max.	Min.	Max.
k	Total length with leg rests	mm	1070	1120	1150	1200
j	Total length without leg rests	mm	780		850	
b	Total width ¹	mm	590	650	760	800
i	Total height	mm	890	920	920	950
	Length folded	mm	780		850	
	Width when folded	mm	310		340	
i	Height folded	mm	890	920	920	950
	Total mass ²	kg	17.6	18.8	25.0	25.1
	Mass of the heaviest part ³	kg	12.6	13.7	18	18.1
	Static stability downhill ⁴	°	10		10	
	Static stability uphill ⁴	°	10		10	
	Static stability sideways ⁴	°	10		10	
	Seat plane angle °	°	3		3	
f	Effective seat depth (adjustable)	mm	400	440	400	440
a	Effective seat width	mm	397	517	567	607
d	Seat surface height (front edge) ⁵	mm	480	510	440	470
g	Seatback angle (with lumbar kink)	°	3 (10)		3 (10)	
h	Backrest height	mm	400		430	
c	Footrest to seat distance	mm	420	510	420	510
	Leg rest angle relative to seat	°	110		110	
e	Armrest to seat distance (adjust.)	mm	240		230	
	Armrest length from back frame	mm	330	380	330	380
	Push rim diameter	mm	530		530	
	Horizontal position of axle	mm	-35	35	45	
	Minimum turning radius	mm	1160	1180	1283	1318
	Maximum user weight ⁶	kg	130	140	170	200

¹ The total width of 71 cm exceeds the recommended dimension of 70 cm stipulated by DIN EN 12183.

² Wheelchair mass standard version without drum brakes

³ Wheelchair weight minus removable parts (without rear wheels and without leg rests)

⁴ The static stability indicates the wheelchair's tipping resistance on slopes and gradients.

⁵ The seat height is measured according to ISO 7176-7 at the center of the front edge of the textile seat covering.

⁶ Maximum user weight including any load. 125kg up to SB 45 | 130 kg from SB 48 (Double cross brace)

Technical specifications		CANEO_S	CANEO_E	CANEO_L	CANEO_B	CANEO_XL
Wheelchair frame colour		Ivory			Anthracite	Ivory
Nominal seat width	mm	360 / 390 420 / 450 480 / 510	390 420 / 450 480 / 510	450 480 / 510	390 420 / 450 480 / 510	560 / 600
Arm cushion (L x W)	mm	370	370	370	370	370
Push handle height ⁷	mm	830-1020	830-920	960-1005	890-920	920-950
Rear wheels (Ø outer x W)	"	24 x 1 ³ / ₈	24 x 1 ³ / ₈	24 x 1 ³ / ₈	24 x 1 ³ / ₈	24 x 1 ³ / ₈
Front wheels (Ø outer x W)	"	7 x 1 ³ / ₄	7 x 1 ³ / ₄	7 x 1 ³ / ₄	7 x 1 ³ / ₄	7 x 1 ³ / ₄
Steepest slope on which parking brakes can be used	°	10	10	10	10	10
Leg rest mass	kg	0.7	0.7	0.7	0.67	0.83
Rear wheel mass	kg	1.86	1.86	1.86	1.86	2.2
Side panel mass	kg	1.15	0.94	1.15	0.94	1.34

⁷ The push handle height depends on the seat height adjustment. The CANEO_S has continuously height-adjustable push handles.

Note: Depending on the design/configuration, the wheelchair may exceed the recommended overall dimensions according to DIN EN 12183.

Materials	CANEO_S	CANEO_E	CANEO_L	CANEO_B	CANEO_XL
Frame, backrest tubes	Aluminium			Steel	
Seat/back upholstery	300 D Polyester				
Armrests	PU foam				
Cross brace	Steel, painted				
Screws, joints	Galvanised or burnished steel				
Tyres on rear/front wheels	PU plastic				
Therapy tray	Acrylic glass				
Leg rests	Aluminium, plastic				

Note: All metals used are corrosion-resistance.

Further information

Operating temperature	-10 C° to +50 C°
Storage conditions	0°C to 45°C 20% to 75% relative humidity
Test dummy weight	130 kg
Crash test dummy	H3 50% dummy (78 kg)

Product tests: The CANEO wheelchair fulfill the requirements of the international standards

DIN EN 12183	the standards for manual wheelchairs have been tested
ISO 7176-8	the static load capacity, shock resistance and fatigue strength have been tested
EN 1021-2	resistance to inflammation has been tested for upholstery materials and plastic components
ISO 10993-5	tested for toxicity in the material

SAFETY INFORMATION & DRIVING RESTRICTIONS

When using the wheelchair, always observe the following safety information to prevent falls, hazardous situations and damage to the wheelchair:

- ▼ Before using the wheelchair for the first time, practice moving on level, clearly laid out terrain. Intensively familiarise yourself with its braking and acceleration behaviour when moving straight ahead and on cornering. An accompanying person is recommended.
- ▼ Never leave children or adolescents in the wheelchair without supervision.
- ▼ Always lock the brake before you sit down or get up from the wheelchair.
- ▼ Never use the wheelchair under the influence of alcohol or other substances which influence attentiveness or physical and mental receptiveness.
- ▼ Please note that the risk of tipping can increase if the balance is shifted due to bodily movements or placing loads on the wheelchair. Adjusting the wheelchair settings to their extremes increases the risk.
- ▼ With an incline / slope of more than 10° there is an increased risk of tipping backwards or forwards, DIETZ recommends using anti-tipping supports.
- ▼ Anti-tip supports must be used for wheelchair configurations that are prone to tipping even on gradients/inclines of less than 10°. They must be properly mounted.
- ▼ The use of ramps is essential for any obstacles.
- ▼ If they cannot be bypassed, ruts, rails or similar obstacles must always be crossed at right angles (90°).
- ▼ Do not propel your wheelchair forward against kerbs, edges or other obstacles without braking.
- ▼ Do not jump from obstacles (edges, steps etc.) while sitting in the wheelchair.
- ▼ Do not stand on the foot plates or footboard while getting up or sitting down.
- ▼ Observe the road traffic regulations when moving in road traffic.
- ▼ Wherever possible, wear light, eye-catching clothing. You will then be seen more easily by other road users.
- ▼ Avoid exposing the wheelchair to direct sunlight / low temperatures for long periods of time, as parts of the product (eg frames, footrests, brakes and side panels) may become very hot (> 41° C) or very cold (<0°) and may cause skin injuries.

- ▼ Always remember that there is a risk of fingers or other parts of the body getting caught in any of the moving parts (brakes, leg rests etc.) while the wheelchair is stationary or when it is moving. For this reason, operate the wheelchair with care.
- ▼ Ensure that the wheelchair is not parked in direct vicinity of emergency exits and escape routes and blocks them.
- ▼ Never exceed the max. load for driver and stowed objects as this can lead to injury or damage to the chair.
- ▼ Avoid escalators. The risk of falling and injury is significantly higher.
- ▼ Stairs must only be negotiated with the help of accompanying persons if no elevators or ramps are present.
- ▼ Never lift the wheelchair with occupants by the wheels or legrests, if necessary only by the fixed components such as the side frame.
- ▼ Any severe incidents associated with the product must be reported to the manufacturer and responsible authority.
- ▼ Protect the wheelchair and its materials against direct sunlight, excessively cold or warm temperatures and excessively high or low humidity if the wheelchair is stored for longer periods.
- ▼ The wheel bearings can be damaged by sand, seawater and road salt. The wheel bearings and the product can be damaged by sand, seawater and road salt. Clean the wheelchair thoroughly if it has been exposed to conditions such as these.
- ▼ If redness, irritation of the skin occurs in connection with the use of the product, consult a doctor immediately.
- ▼ If your product is custom-made (see product labelling), the additional documentation including all safety instructions must be observed in addition to the current operating instructions.

SERVICING/MAINTENANCE

We recommend performing the inspections listed in the maintenance schedule at regular intervals to ensure that the wheelchair is always safe to use.

Defective or neglected care and maintenance of the wheelchair limits liability. The maintenance schedule does not give any information concerning the amount of work actually required on the wheelchair.



NOTE

As the user, you will be the first to notice possible damage. If you notice a fault as described in the maintenance schedule or further defects and functional impairments, contact an authorised specialist dealer immediately. _____



NOTE

The inspections and measures stipulated in the maintenance schedule must be performed by the user or assistant if not otherwise stated. ____



WARNING



Repairs on the wheelchair must only be performed by specialist shops using DIETZ original spare parts to maintain the operational safety of the wheelchair. The relevant service manual and spare parts catalogue can be found on our website in the information of the product in question. _____





NOTE FOR SPECIALIST DEALERS:

If the user indicates abnormalities on the wheelchair, check all the inspection points listed in the maintenance schedule on the wheelchair. The checks must also be performed before putting the wheelchair back into operation and after longer storage periods (> 4 months). ____

MAINTENANCE SCHEDULE

What	Description	Monthly	
		Daily / before using	
Parking brakes Check for correct function	<ul style="list-style-type: none"> The wheels must not turn if the parking brakes are locked.  The parking brakes must be reset after being replaced or if the position of the rear wheels has been changed. This must only be performed by the authorised specialist retailer.	x	
Drum brake (optional) Check for correct function	<ul style="list-style-type: none"> The braking effect must be present when the brake lever is actuated. The wheels must be firmly blocked when the drum brake is locked. The Bowden cable must not be damaged.  The drum brakes must be reset after being replaced or if the position of the rear wheels has been changed. This must only be performed by the authorised specialist retailer.	x	
Seat and backrest upholstery Check for contamination/damage	<ul style="list-style-type: none"> If contamination is found, clean the upholstery in line with the cleaning information. If the upholstery is damaged, have it replaced. 	x	
Moving parts Check for correct function and wear	<ul style="list-style-type: none"> Check that all moving parts (leg rests, foot plates, side panels, height-adjustable push handle) function smoothly and with little noise. 	x	
Screw joints Check that they are firmly seated	<ul style="list-style-type: none"> All screw joints must be firmly tightened.  Self-locking nuts and screws lose their efficacy through being repeatedly released and tightened. Therefore, they must be replaced by an authorised specialist dealer.	x	
Wheels Check for correct function and damage	<ul style="list-style-type: none"> The wheels must run straight and not wobble. The wheels must move easily and with little noise when travelling. The wheels must be replaced if damaged. 	x	
Tyres (PU) Check for correct function and damage	<ul style="list-style-type: none"> Damaged or worn tyres must be replaced. 	x	

What	Description	Monthly	
		Daily / before using	
Pneumatic tyres (optional) Check for correct function and damage	<ul style="list-style-type: none"> • Check the tyre pressure • Pump the tyres up to the required pressure (see information printed on the side of the tyre). • Damaged or worn tyres must be replaced.  In case of air loss, the wheelchair can no longer be used as safe driving is not ensured.	x	
Push handle Check for correct function and wear	<ul style="list-style-type: none"> • The handles must be firmly attached. • The push handles must be at the same height and not show any obvious damage/distortion. • It must be possible to lock the fixing screw firmly (for optional height-adjustable push handles). 		x
Side panel, complete Check for correct function and damage	<ul style="list-style-type: none"> • It must be possible to remove, attach and lock the side panels without fault. • Defects and surface defects must be remedied. 		x
Leg rest/foot rest Check for correct function and damage	<ul style="list-style-type: none"> • It must be possible to remove, attach and lock the leg rests without fault. • Defects and surface defects must be remedied. 		x
Push rims Check for damage and wear	<ul style="list-style-type: none"> • The push rims must be firmly screwed to the wheels.  Danger of injury! Surface damage to the push rims must be remedied immediately.		x
Folding mechanism Check for smooth movement	<ul style="list-style-type: none"> • The wheelchair must fold up soundlessly. 		x
Wheels Check the wheels for correct function, damage and correct seating	<ul style="list-style-type: none"> • The spokes must not be loose, warped or broken. • Remove dirt and deposits from the quick-release axles and wheel hubs. • The wheel must not come free if the rear wheel is pulled to the side. 		x
Visual inspection , check for loose parts, breaks, corrosion or other damage	 If damage of this type is found, the wheelchair must no longer be used as safe driving is not ensured.		x
Cleaning Check for contamination	<ul style="list-style-type: none"> • The entire wheelchair must be cleaned as necessary depending on the level of contamination but at least once per month (see chapter Cleaning instructions). 		x

TROUBLESHOOTING

What	Possible causes	Measures
The rear wheels do not run straight	<ul style="list-style-type: none"> The spokes are loose, warped or broken. 	Visit an authorised specialist dealer
The wheelchair does not move in a straight line	<ul style="list-style-type: none"> The wheels have different tyre pressures (only if optional pneumatic tyres have been selected). 	Correct the tyre pressure
	<ul style="list-style-type: none"> The wheel axles are dirty. 	Remove the dirt.
	<ul style="list-style-type: none"> The wheels are adjusted differently. The wheels are worn or damaged. The bearings of the front wheel fork cannot turn freely. The wheel bearings of the front wheels are dirty or damaged. 	Visit an authorised specialist dealer
The wheelchair is difficult to push	<ul style="list-style-type: none"> The wheel axles are dirty. 	Remove the dirt.
	<ul style="list-style-type: none"> The tyre pressure of the wheels is too low (only if optional pneumatic tyres have been selected). 	Correct the tyre pressure
	<ul style="list-style-type: none"> The brakes are set incorrectly. 	Visit an authorised specialist dealer
The front wheels are stiff or jam	<ul style="list-style-type: none"> The bearings are dirty or defective. 	Visit an authorised specialist dealer
Brake function is insufficient and uneven	<ul style="list-style-type: none"> The tyre pressure of the wheels is too low (only if optional pneumatic tyres have been selected). 	Correct the tyre pressure
	<ul style="list-style-type: none"> The brakes are set incorrectly. 	Visit an authorised specialist dealer
Squeaking and grinding noises	<ul style="list-style-type: none"> Various causes 	Visit an authorised specialist dealer



WARNING

Material damage: Do not use high-pressure cleaners, strong, corrosive chemicals or scouring agents for cleaning purposes.

Risk of corrosion: After cleaning, ensure that all materials are completely dried in order to preserve their quality. _____



WARNING

Safe disinfection cannot be guaranteed on upholstery parts featuring seams and textiles. In this case we recommend to replace these parts.

Material damage: Observe the use and processing instructions issued by the cleaning agent/disinfectant manufacturer.

Risk of infection: The product must be disinfected before each change of user. _____

CLEANING

The wheelchair's frame parts can be wiped down with a damp cloth. A mild cleaning agent can be used in the case of more severe soiling.

The wheels can be cleaned using a damp brush with soft plastic bristles (do not use a wire brush!).

The upholstery materials can be washed by hand using mild soapy water at 40°C.

DISINFECTION

When manually reconditioning a used aid for reuse, all of the aid's components must be thoroughly treated/wiped with a disinfectant. Take particular care to disinfect surfaces that come into frequent contact with hands/skin, such as handles and armrests.

Please only use the following disinfectants; use of other chemicals might damage the wheelchair.

- ▼ Aldehyde-free disinfectants based on alcohol (max. 70% propyl alcohol)

DISPOSAL

If you no longer need the wheelchair, please contact your specialist dealer. They will then pick up the wheelchair and either dispose of it properly or make further use of it. If this is not possible, please take the wheelchair to your local recycling facility.

FORWARDING / REUSING

The wheelchair is ideal for use as a loaned wheelchair or for short-term use.

The number of times it can be reused depends on the material wear conditions and the functional capabilities of the respective product. If the wheelchair is passed on to a new user or specialist dealer for reuse, please remember to hand over all technical documents that are necessary for safe usage.

The wheelchair must be cleaned and disinfected, and must be checked for damage and approved by the specialist retailer.

To do this, all test points listed in the maintenance plan must be checked on the wheelchair.

STORAGE

To store the wheelchair, ensure that the wheelchair is stored in a dry place protected against direct, strong sunlight and at a temperature of 0°C to +45°C. Do not activate the parking brakes. Secure the wheelchair against rolling away unintentionally.

After longer periods of storage (> 4 months), please check all the inspection points on the wheelchair listed in the maintenance schedule before reusing/redeploying the chair.



WARNING

Risk of infection: The product must be disinfected before each change of user. This is important to avoid cross-contamination. _____



NOTE

If the product is marked as a custom-made product, it cannot be passed on or reused. _____



WARNING

Do not store the wheelchair near a heat source or store objects on the wheelchair. _____

PRODUCT LABELLING

Stickers must remain legible and not be removed. Immediately replace illegible or missing stickers. The serial number sticker is very important for identifying the product, it is placed on the product label, which is placed below the seat on the cross strut. It must not be removed.

Further markings on the product:

SONDERANFERTIGUNG
CUSTOM-MADE DEVICE

For custom models, which were customer made for a particular user, the product label, intended purpose and warnings are different. Please pay attention to the additional documentation!



Wheelchair crash tested according to ISO 7176-19 and suitable for transporting persons in vehicles/markings of the attachment points for the wheelchair restraint system on the wheelchair



Crash tested according to ISO 7176-19





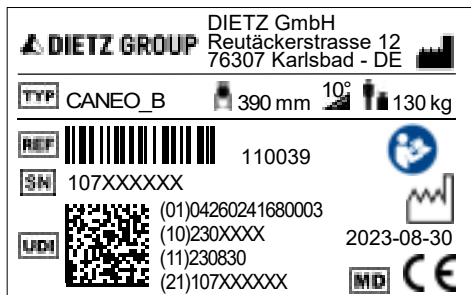







Not approved as a seat for transporting passengers in a vehicle. Models marked with these labels have not been crash tested.



Example product label; CANEO_B

fig.59

-  Type/model
-  REF = Item number
-  SN = Serial number
-  UDI = Unique device identifier
 - (01) UDI-DI / GTIN
 - (10) Order number
 - (11) Date of manufacture (YYMMDD)
 - (21) Serial number
-  Seat width
-  Manufacturer/manufacturer's trademark/contact address
-  Max. Maximum user weight incl. payload/add-ons
-  Date of manufacture
-  Maximum safe gradient that can be driven on with the wheelchair*
-  Follow the user instructions
-  Medical Device

* Depends on the wheelchair settings and user's abilities

WARRANTY

Warranty services refer to all product defects which are verifiably attributable to material or manufacturing flaws. The warranty period is 24 months as of receipt of notification of readiness for shipping, but following delivery at the latest. Damage which has occurred due to natural wear, intent, and negligent or improper operation or usage is excluded from the warranty obligation. This also applies to the use of unsuitable care products, lubricating oils or greases.

LIFETIME

The expected product service life is five years when used daily and if used as intended. This assumes compliance with the maintenance and safety specifications stipulated in this manual.

LIABILITY

The DIETZ GmbH is only liable if the product is used under the specified conditions and for the specified purpose. We recommend that the products be handled appropriately and cared for according to the instructions. DIETZ GmbH is not liable for damage caused by components and spare parts that have not been approved by DIETZ GmbH. Repairs must only be carried out by authorised specialist retailers or by the manufacturer itself.

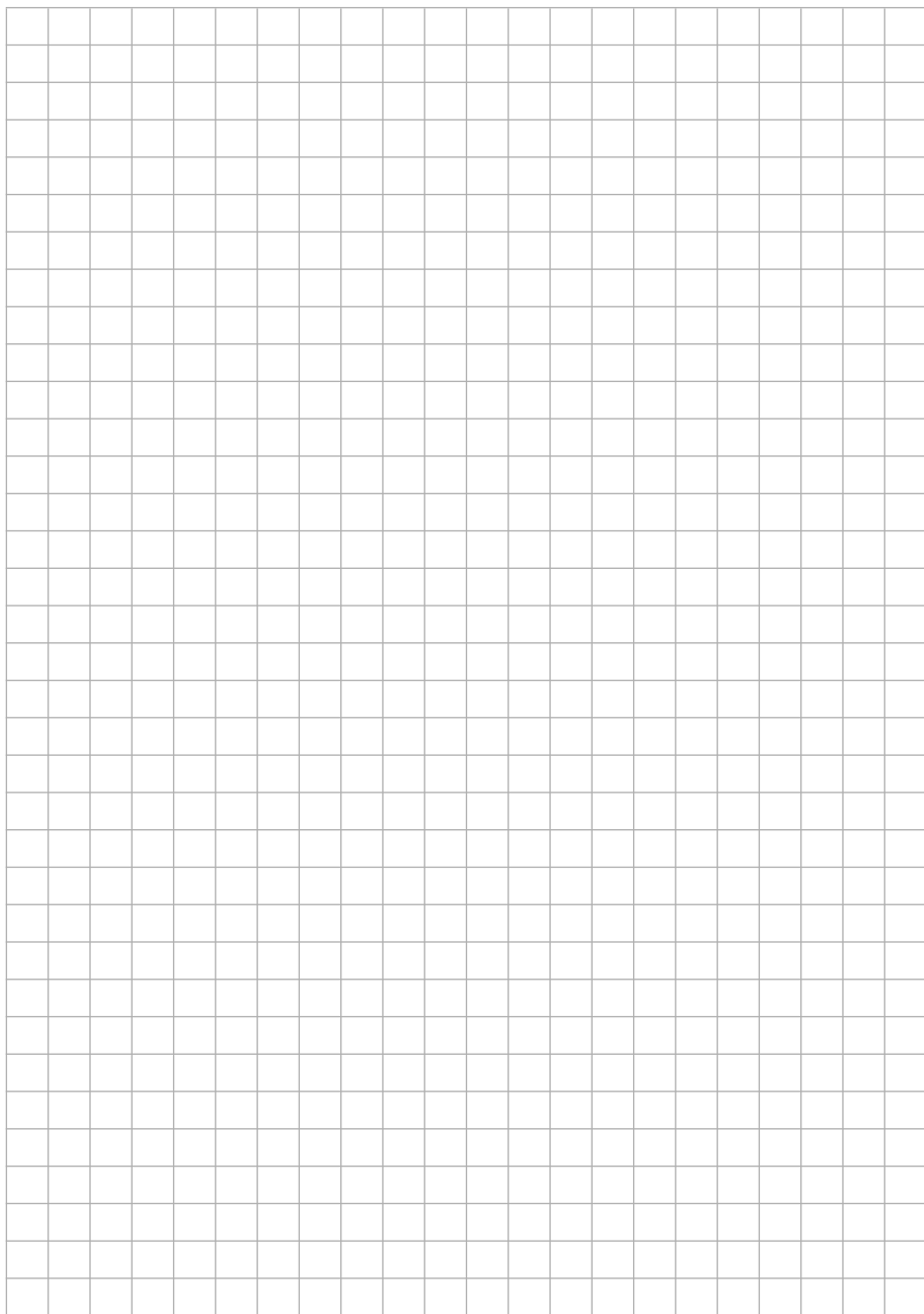

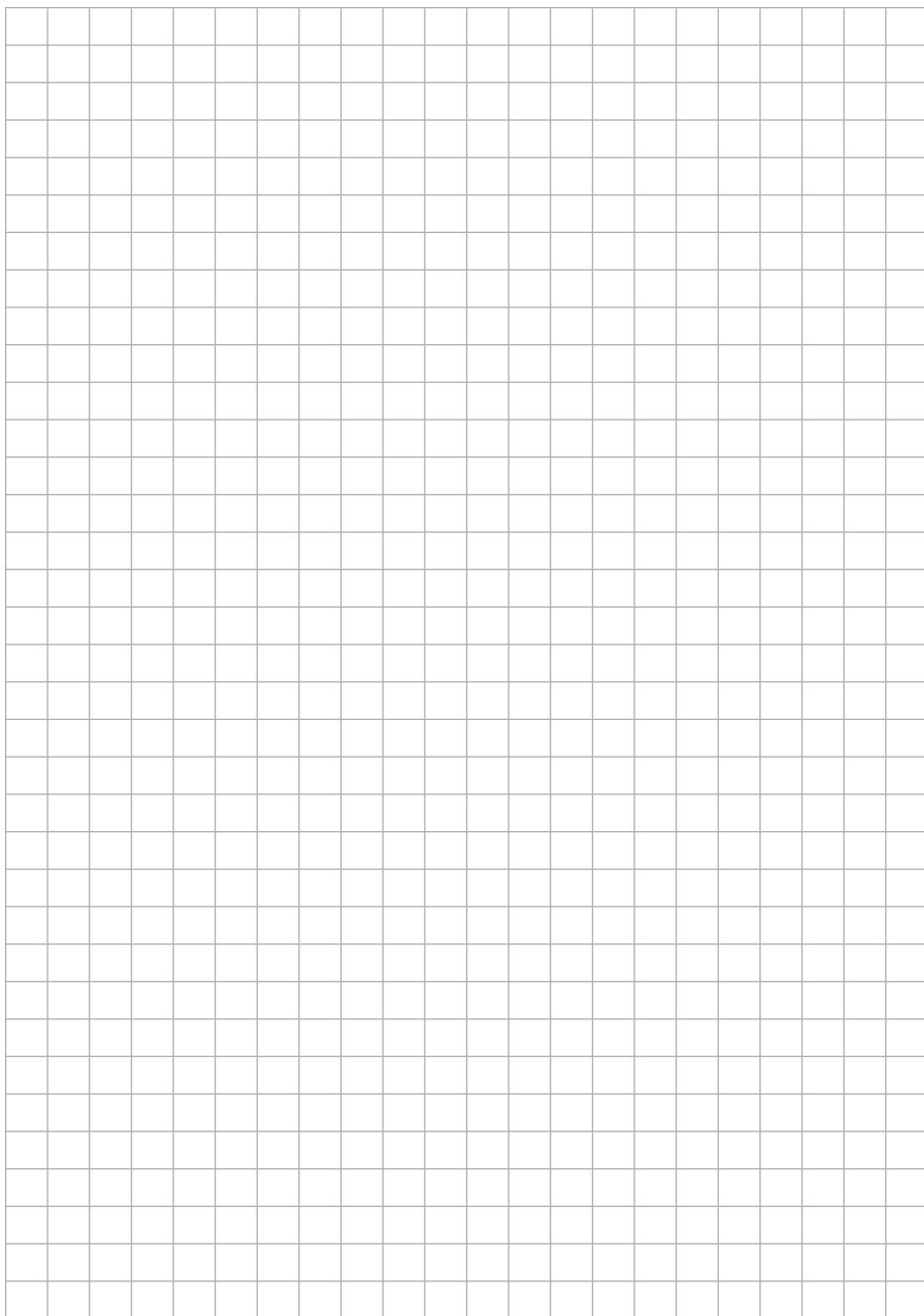



Product group: Manual wheelchairs

Product: CANEO_B/_S/_E/_L/_XL

User manual Version 2.0 EN

As of 2023-09 (RPO)

DIETZ GmbH

Reutäckerstraße 12

76307 Karlsbad

Germany

Tel.: +49 7248.9186-0

Fax: +49 7248.9186-86

info@dietz-group.de

www.dietz-group.de



DIETZ GmbH
Reutäckerstraße 12
76307 Karlsbad
Deutschland