

KANJO

Bath lift

User manual version 6.1

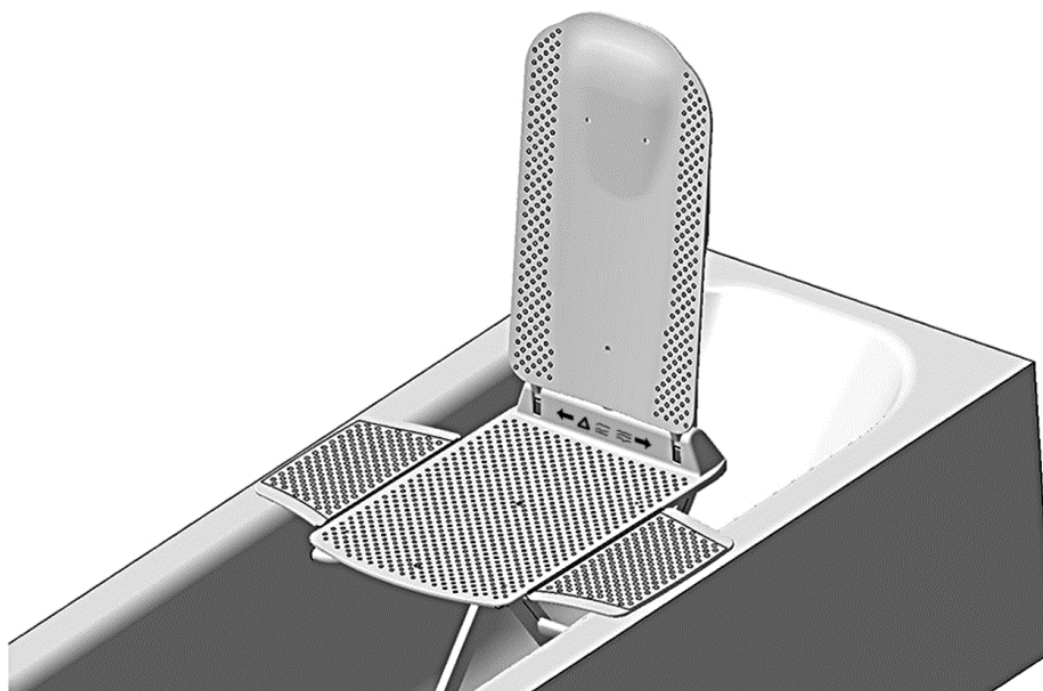

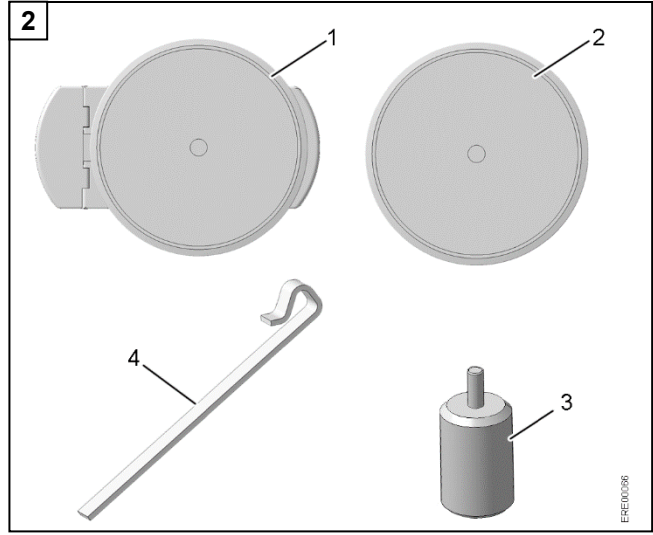
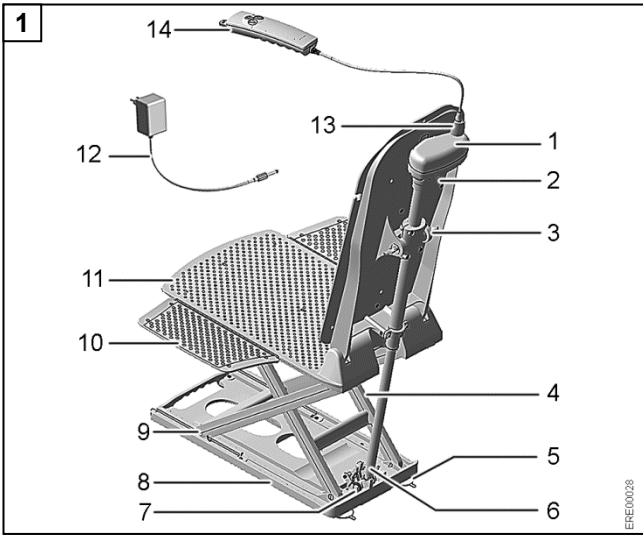

3

DIETZ GROUP DIETZ GmbH
Reutäckerstrasse 12
76307 Karlsbad - DE

16 **TYP** Modell
15 **REF** XXXXXX
14 XXXXXX
13 YYY-MM-DD
12 **SN** BLVXXXXXXXXXX
11 **UDI** 10,5 kg
10 (01)XXXXXXXXXXXX
(10)XXXXXX
(11)YYMMDD
(21)BLVXXXXXXXXXX

1 XXXkg
2 XXXkg
3
4 YYY-MM-DD
5 XX.X VDC/6A
6 10,5 kg
7 O=90%
I=10%
8 **IP X6**
9 **MD**

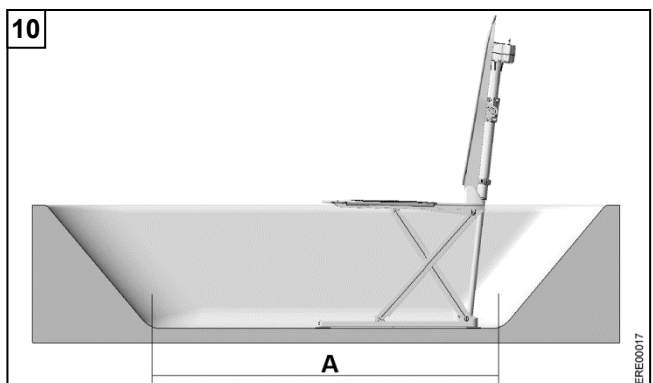
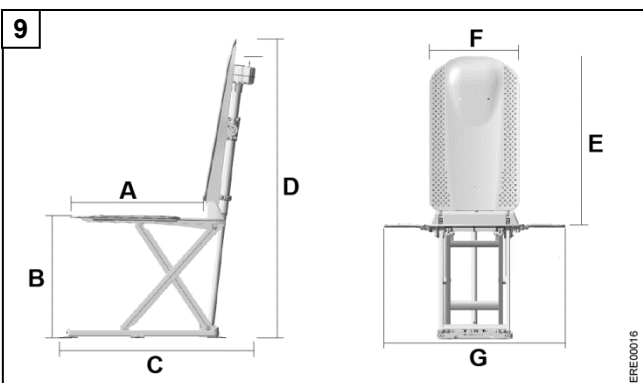
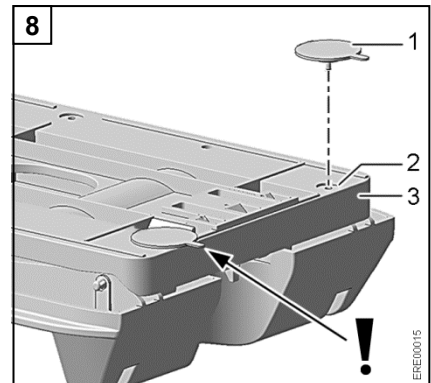
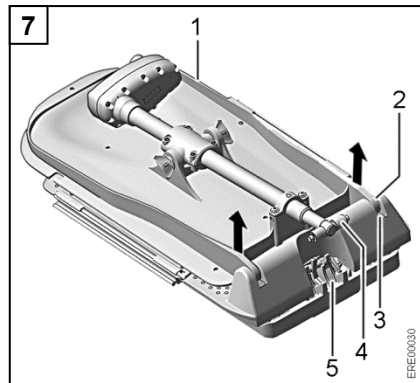
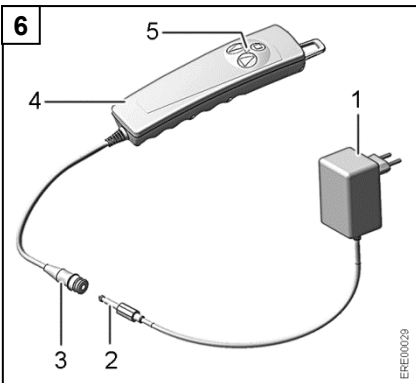
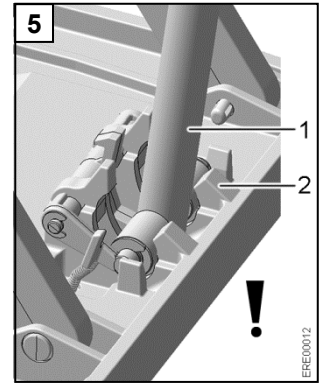
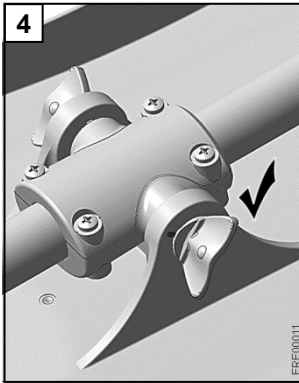

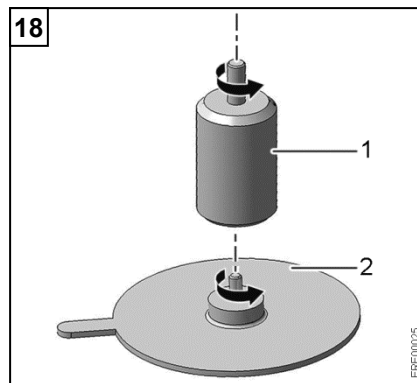
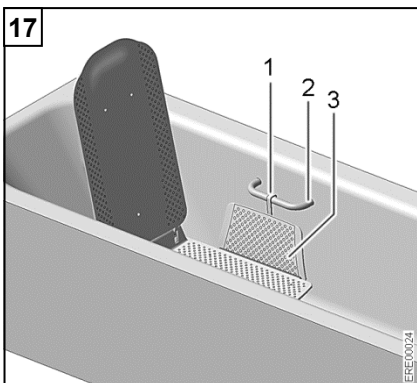
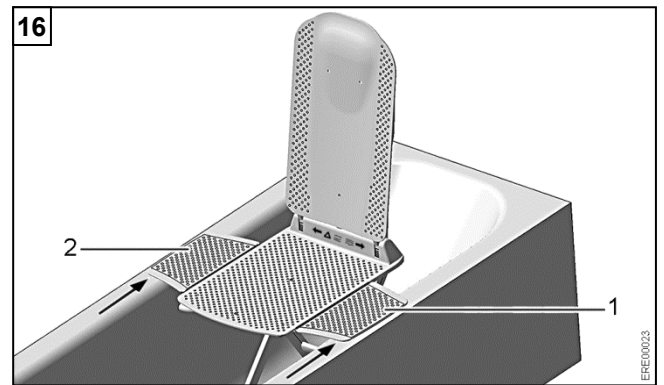
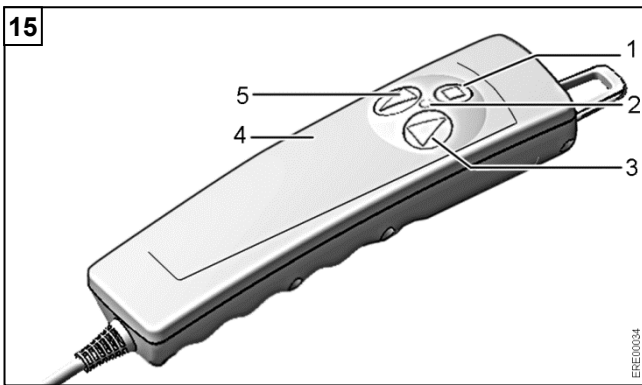
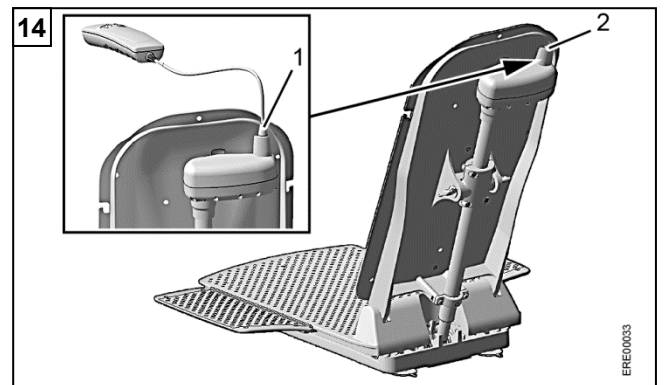
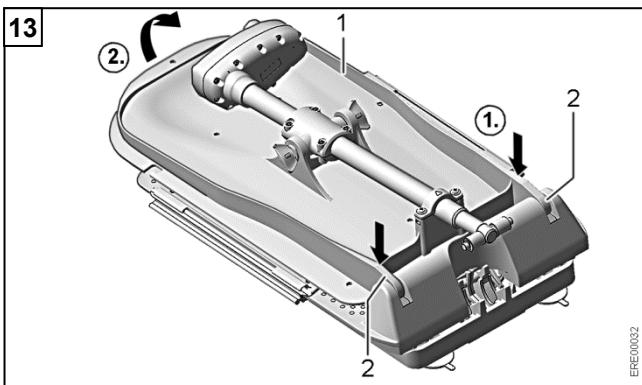
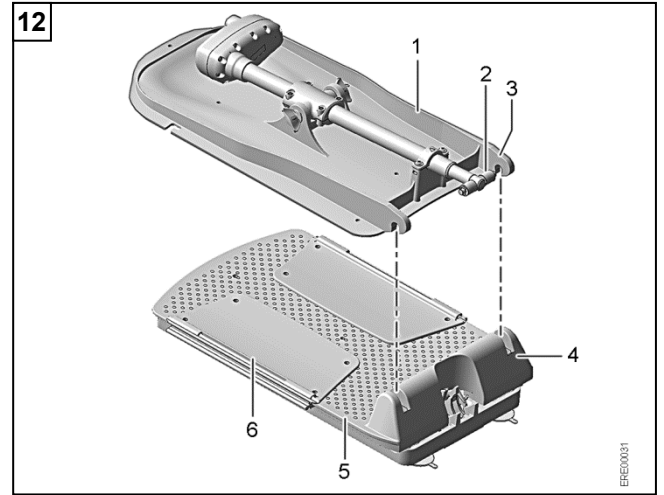
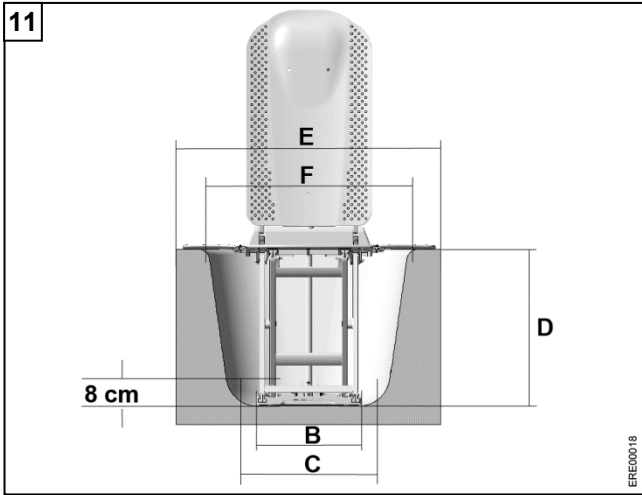

Contents

1	Basic information	5
1.1	Introduction	5
1.2	Intended use	5
1.3	Intended user group	5
1.4	Intended place of use	5
1.5	Indication	5
1.6	Contraindications	5
1.7	Disposal	5
1.8	CE marking	5
1.9	Reuse/conditioning	5
1.10	Service life	6
2	Safety instructions	6
2.1	Warnings and symbols	6
2.2	General safety information	6
2.3	Safety information on electromagnetic compatibility	6
3	Description.....	7
3.1	Scope of delivery	7
3.2	Accessories	7
3.3	Type label	7
3.4	Technical specifications.....	7
4	Transport and storage.....	9
5	Preparing the bath lift for use	9
5.1	Charging the handheld remote battery	9
5.2	Attaching the suction feet	9
5.3	Installing the seat unit in the bath	9
5.4	Mounting the backrest	10
5.5	Checking before use.....	10
6	Operating the bath lift	10
6.1	Handheld remote	10
6.2	Raising the seat.....	11
6.3	Lowering the seat	11
6.4	EMERGENCY STOP function	11
7	Bathing	11
8	Disassembling the bath lift	11
9	Troubleshooting	12
10	Maintenance and care	12
10.1	Cleaning the seat unit and backrest	12
10.2	Cleaning the handheld remote and charger	13
10.3	Disinfecting	13
10.4	Maintenance and inspections	13
11	Mounting accessories	13
11.1	Mounting the side flap diverters	13
11.2	Mounting the height adapter	14
12	Warranty.....	14
13	Liability.....	14

1 Basic information

1.1 Introduction

This user manual contains information on using the bath lift safely and properly and must be handed over to the user of the bath lift.

For information on the intended user group, see (section 1.3).

Read the user manual carefully before using the bath lift for the first time and observe all instructions, especially the safety instructions.

If you have problems understanding this user manual, ask a qualified healthcare professional for assistance. Do not use the bath lift until you have understood the instructions and safety instructions contained in this user manual.

If you need further information or have any questions about product safety or recalls, please contact DIETZ GmbH in writing or by telephone. Our contact information can be found at the end of the user manual. The current user manual and further information on the bath lift can be found on our website.

The user manual are also available as a PDF file with zoom function for visually impaired persons from www.shop.dietz-group.de.

If reference is made to illustrations in the text, these references are structured as follows: **(figure 3,1)** means item 1 in figure 3.

1.2 Intended use

The bath lift is intended exclusively for bathing people inside a bathtub. The person being bathed must still have sufficient control of their trunk and residual functional capacity of the extremities.

Any use other than indicated is not permitted.

1.3 Intended user group

The user group includes people with restricted mobility, e.g. of the legs and/or hips (= patients).

If the bath lift is used without an attendant, the patient must be able to maintain their balance.

The intended user group may also include carers who operate the bath lift. Severely disabled persons may only be bathed with the supervision of a carer

The bath lift must not be used by children. The bath lift is not suitable for people less than 146 cm in height or who weigh less than 40 kg (BMI < 17).

1.4 Intended place of use

Locations in which the bath lift is intended to be used include retirement and nursing homes, hospitals, rehabilitation centres and private households.

1.5 Indication

Treatment using the bath lift is indicated for patients with:

- Damage to the lower and upper extremities with limited or partially reduced mobility and muscle strength
- Damage to vestibular functions with a tendency to fall (impaired balance)
- Damaged muscle functions with sufficient trunk stability

1.6 Contraindications

The bath lift is unsuitable for patients with:

- False sensations
- Severe disequilibrium
- Inability to sit
- User weight exceeding 140 kg or 170 kg (version XL)
- Height <146 cm and/or weight <40 kg (BMI <17)

1.7 Disposal

Old appliances and packaging must be disposed of and recycled in accordance with the applicable national regulations.

The product is made from recyclable materials and fulfils the requirements of the WEEE Directive and the RoHS Directive.

The bath lift contains a rechargeable lithium-ion battery. Lithium-ion batteries contain substances that can be harmful to the environment. Therefore, these batteries must not be disposed of in normal household waste. Instead, they must be disposed of separately in accordance with national regulations.

1.8 CE marking

The technical requirements for the device are set out in DIN EN ISO 10535 (lifts) and are met. The product complies with the Medical Device Regulation (EU) 2017/745.

1.9 Reuse/conditioning

⚠ WARNING The bath lift must be disinfected before every change of user. This is important for avoiding cross-contamination. There is a risk of infection.

The bath lift is suitable to be passed on and re-used. The number of times the lift can be reused depends on the level of material wear and the functional suitability of the bath lift in question. When handing over the product to a new user or specialist dealer, please also hand over all technical documentation required for safe handling of the device.

The bath lift must be cleaned, disinfected, inspected for damage and approved by a specialist dealer before being used again.

In Germany the DIETZ Group offers a professional hygiene service for reconditioning the devices in accordance with the MDR. Further information can be requested from kundenservice@dietz-group.de.

1.10 Service life

The bath lift is designed to withstand a service life of 5 years if used as intended and if **all** maintenance and inspection intervals are observed.

Further use or inspection/repair of the product after this period is conducted at the discretion and responsibility of the operator.

2 Safety instructions

2.1 Warnings and symbols

The warnings in this user manual are labelled with the categories Warning, Caution and Notice.

⚠ WARNING indicates a potentially hazardous situation. Failure to observe the warning may result in death or serious injury.

⚠ CAUTION indicates a potentially hazardous situation. Failure to observe the warning may result in injury.

NOTICE indicates a potentially hazardous situation. Failure to observe the warning may result in damage to the product.

2.2 General safety information

Only use the bath lift for bathing people inside a bathtub.

Do not use the bath lift as a climbing aid, as a support, as a lifting platform or for similar purposes.

Children must not use the bath lift (see section 1.3).

Do not reach under the seat plate or between the edge of the bath and the bath lift while the seat of

the bath lift is being raised or lowered. Danger of crushing!

Only use the bath lift in bathtubs that have the specified dimensions (see section 5.3).

Persons with limited mobility and impaired physical functions should only use the bath lift under supervision.

If the appliance is used without supervision, ensure that the user can reach an alarm system or telephone in case of an unforeseen event occurring (e.g. malfunction).

Maintain a relaxed sitting position while using the bath lift. Avoid extreme movements of the body.

Do not overload the bath lift. Read the information on the rating plate (see section 3.3).

Check the bath lift for defects before every use.

Do not use the bath lift if it is defective.

Contact a specialist dealer immediately if a malfunction occurs.

Do not make any unauthorised changes or modifications to the bath lift.

Only use original parts and accessories made specifically for the bath lift by DIETZ GmbH.

Make sure that objects that are put into the bath (e.g. brushes) do not get stuck in the scissor lift area. If objects become jammed in the area of the scissor lift, do not lower the seat of the bath lift any further.

Check the position of the bolts on the spindle lock before every use (see figure 4).

The drive is resistant to jets of water, but not to being submerged. Do not immerse the drive in water.

Do not throw the handheld remote into a fire or store it near intense heat sources. Danger of explosion.

Hot water, sunlight or hot air can cause the surface of the product to become hot. Risk of burns!

Any severe incidents associated with the product must be reported to the manufacturer and responsible authority.

2.3 Safety information on electromagnetic compatibility

This product fulfils the standard DIN EN 60601-1-2 Medical electrical equipment Part 1-2 (Electromagnetic compatibility). However, special precautions must be taken when using the product.

Do not use mobile phones or other devices that generate strong electrical or electromagnetic fields in the vicinity of the bath lift. Devices such as these could cause the bath lift to malfunction and create a potentially unsafe situation. If possible, keep these kinds of devices a minimum of 2 metres away from the bath lift.

3 Description

This bath lift is an electrically powered bath lift that helps people with limited mobility to get in and out of the bathtub. The bath lift can be lowered into or raised out of the bathtub using a remote control (called the handheld remote in this user manual). The angle of the backrest can also be changed using the handheld remote. A battery in the handheld remote supplies the bath lift drive with power.

The bath lift is available in the following versions:

- POWER
- ECO
- B-protect (with antimicrobial coating)
- XL

3.1 Scope of delivery

The following components are included with the bath lift (figure 1):

- 1 Drive
 - 2 Backrest¹
 - 3 Bolt spindle lock (2 pieces)
 - 4 Scissor lift
 - 5 Suction feet (4 pieces)
 - 6 Drive unit foot
 - 7 Drive unit foot mount
 - 8 Base plate
 - 9 Sliding block
 - 10 Side flaps (2 pieces)
 - 11 Seat plate¹
 - 12 Charger
 - 13 Jack plug
 - 14 Handheld remote with spiral cable¹
- User manual (not shown)

Some details of the illustrations may be different from the actual state of construction.

¹ Applied part

3.2 Accessories

The following accessories are available for the bath lift (figure 2):

- 1 Swivel/transfer aid
- 2 Swivel aid
- 3 Height adapter
- 4 Side flap diverters

3.3 Type label

The type label (figure 3) is attached to the rear of the backrest. The type label shows the following information (example illustration):

- 1 Manufacturer / manufacturer's logo / contact address
- 2 Max. user weight
- 3 Follow the user manual
- 4 Date of manufacture (YYYY-MM-DD)
- 5 Rated voltage/rated input
- 6 Duty cycle
- 7 Protection class
- 8 The product is compliant with Regulation (EU)2017/745 on medical devices.
- 9 Medical device
- 10 UDI = Unique device identifier
(01) UDI-DI / GTIN
(10) Batch / lot number
(11) Date of manufacture (YY-MM-DD)
(21) Serial number
- 11 Weight of seat and backrest unit
- 12 SN = serial number
- 13 WEEE marking
- 14 Type B applied part
- 15 REF = Item number
- 16 TYPE = model

3.4 Technical specifications

Bath lift (figure 9)

Total weight	11.12 – 11.36 kg ² (24.52- 25.04 lbs)
Seat unit weight	6.76 kg ² (14.90 lbs)
Backrest weight	3.63 kg ² (8.00 lbs)
Handheld remote (ECO) weight ³	0.47 kg ² (1.04 lbs) (0.42 kg ²) (0.93 lbs)
Suction feet weight	0.10 – 0.16 kg ² (0.22- 0.35 lbs)
Covers weight	0.12 – 0.19 kg ² (0.26- 0.42 lbs)
Weight of power supply unit(s)	0.09 – 0.11 kg ² (0.20- 0.24 lbs)
Seat depth (A)	500 mm (19.7 in.)
Max. seat height (B)	455 mm (17,9 in.)
Min. seat height	65 mm (2.6 in.)
Overall depth (backrest upright) (C)	690 mm (27.2 in.)
Overall depth (backrest lowered)	900 mm (35.4 in.)

Total height (D)	1105 mm (43.5 in.)
Backrest height (E)	680 mm (43.5 in.)
Backrest width (F)	350 mm (13.8 in.)
Seat width with side flaps (G)	710 mm (27.9 in.)
Seat width without side flaps	375 mm (14.8 in.)
Base plate footprint	530 x 220 mm (20.9 x 8.7 in.)
Base plate outer dimensions	565 x 295 mm (22.2 x 11.6 in.)
Backrest adjustment	Up to 40°
Max. user weight	140 kg (308 lbs) XL: 170 kg (375 lbs)
Drive protection class	IP X6 ⁴
Handheld remote protection class	IP X7 ⁵
Overall device protection class	IP X6 ⁴
Operating force for the buttons of the handheld remote	< 5 N
Operating voltage (ECO) ³	14.8 V DC (11.1 V DC)
Rated current	6 A
Duty cycle	10% / 2 min – 90% / 18 min
Lithium-ion battery (ECO) ³	14.8 V DC (11.1 V DC) 2200 mAh
Charging time from low voltage display	approx. 1 h
Sound power level up/down	49/47 dB(A)

² Weight tolerances of + / - 0.05 kg (0.11 lbs) possible.

³ The suffix (ECO) means that the information in brackets applies to the ECO variant of the bath lift. This variant can be recognised by the label reading ECO on the handheld remote.

⁴ IP X6 = Protection against powerful water jets.

⁵ IP X7 = Protection against temporary submersion

Materials

Backrest	PPGF ⁶
Seat unit / scissor lift	PPGF / PA6 GF ⁶
Covers	PU ⁶

⁶ All materials used are corrosion-resistant and latex-free. The materials used fulfil the requirements of the REACH Regulation.

Charger

Input	100-240 V AC / 50/60 Hz
Output	18 V DC / 0.6 A

Ambient operating conditions

Ambient temperature	10 to 40°C (50 to 104 F°)
Relative humidity	10% to 100%
Air pressure	795 hPa to 1060 hPa

4 Transport and storage

Transport the bath lift in its original packaging. Keep the original packaging for later use.

Check the original packaging after transport. If the original packaging is damaged, if it has been unintentionally opened before use or if it has been exposed to environmental conditions during transport that are outside the limits specified below, check whether any parts of the bath lift have been damaged and whether the bath lift is working properly.

Ambient conditions for transport and storage:

Ambient temperature	0 to 40°C (32 to 104 F°)
Relative humidity	30% to 75%
Air pressure	795 hPa to 1060 hPa

5 Preparing the bath lift for use

Before using the bath lift, check that all parts are complete and undamaged.

⚠ WARNING Do not use the bath lift if you see any damage.

5.1 Charging the handheld remote battery

⚠ WARNING Do not use the handheld remote if it is damaged or cracked.

NOTICE Only charge the battery in the handheld remote using the supplied charger. Only charge the battery in a dry room (not in the bathroom). Do not charge the battery while the bath lift is being used. Do not insert any conductive objects (e.g. knitting needles) into the jack socket of the handheld remote cable.

1. Insert the jack plug (figure 6,2) of the charger (figure 6,1) into the jack socket (figure 6,3) of the handheld remote (figure 6,4).
2. Connect the charger (figure 6,1) to the mains power supply. The LED (figure 6,5) will flicker briefly and then light up red. The LED will go out once the battery is fully charged.

Once the battery is charged:

1. Disconnect the charger (figure 6,1) from the mains power supply.
2. Disconnect the handheld remote (figure 6,4) from the charger.

Fully charge the battery in the handheld remote before every use. If the handheld remote is not connected to the charger, do not connect the charger to the mains power supply.

Only use the handheld remote to operate the bath lift.

If the bath lift has not been used for some time, charge the battery and then run the bath lift up and down as far as they will go one time without a load. Repeat this process every 3 months. This has a favourable effect on battery capacity and, therefore, on the service life of the battery.

5.2 Attaching the suction feet

⚠ WARNING If the suction feet are not correctly stuck in place, the bath lift may slip out of position. There is a risk of injury. Make sure that the suction feet are free from dirt and grease. Make sure that the suction feet are not bent.

1. Remove the backrest. To do so, take hold of the backrest (figure 7,1) with both hands close to the locking hooks (figure 7,2). Release the locking hooks from the holder (figure 7,3) by tugging gently.

⚠ CAUTION The drive unit foot mount contains the mechanism for releasing the seat plate lock. If the seat plate lock is accidentally released, the scissor lift can move freely. Limbs can be trapped and bruised. Do not reach into the drive unit foot mount (figure 7,5).

2. Turn over the seat unit (figure 8,3).

NOTICE If the suction feet are not screwed completely into the threaded sleeves and the bath lift is loaded, the base plate may be damaged. Screw the suction feet into the threaded sleeves as far as they will go.

3. Screw all four suction feet (figure 8,1) into the threaded sleeves (figure 8,2) in the base plate. The tabs on the suction feet must point outwards (see figure 8).

5.3 Installing the seat unit in the bath

⚠ WARNING If the suction feet are not correctly stuck in place, the bath lift may slip out of position. There is a risk of injury. Make sure that the floor of the bathtub is smooth, level, dry and clean. Do not install the bath lift in bathtubs with a structured surface (raised bumps). Remove non-slip mats (if present).

Only install the bath lift in bathtubs that comply with the following specifications:

Figures 10 and 11	Description	Dimensions in mm (in.)
A	Length of bathtub bottom	> 800 (31.5)
B	Bathtub width at the bottom (suction feet spacing)	280-610 (11-24)
C	Bathtub width at a height of 80 mm (base plate)	> 420 (16.5)
D	Bathtub height (inside)	< 455 (17.9)
	Bathtub height (inside) when using height adapters (accessories)	475 (18.7)
E	Bathtub width at the top (outside)	< 710 (27.9)
F	Bathtub width at the top (inside)	< 630 (24.8)

If the bathtub is fitted with handles, use side flap diverters (accessories; see section 11.1).

If the bathtub height (inside) is more than 455 mm (17.9 in.): use height adapters (accessories; see section 11.2).

CAUTION The drive unit foot mount contains the mechanism for releasing the seat plate lock. If the seat plate lock is accidentally released, the scissor lift can move freely. Limbs can be trapped and bruised. Do not reach into the drive unit foot mount (figure 7,5).

1. Place the seat unit on the floor of the bathtub. Place the rear suction feet as close as possible to the slope of the bathtub, but not actually **on** the slope (see figure 10).
2. Press the seat unit down gently onto the bathtub floor.
3. Check that the suction feet are sticking to the bathtub floor by tugging gently on the seat unit.

5.4 Mounting the backrest

NOTICE If the drive unit foot of the backrest is not fully retracted during installation, the bath lift may be damaged. Make sure that the drive unit foot is completely retracted. The drive unit foot (figure 12,2) must be horizontal (see figure 12).

1. Place the backrest (figure 12,1) on the seat unit (figure 12,5). The locking hooks (figure 12,3) must engage in the holders (figure 12,4).

2. Press gently on the locking hooks (figure 13,2). The locking hooks must engage audibly.
3. Take hold of the upper end of the backrest (figure 13,1) and move it upwards as far as it will go.
4. Check that the backrest is fitted correctly:
 - Are both locking hooks engaged? (The blue dots on the front of the locking hooks must be visible.)
 - Is the drive unit foot (figure 5,1) properly positioned in the drive unit foot mount (figure 5,2)?
 - Is there a distance of at least 25 mm (0.98 in.) between the handheld remote connection and the wall?
5. Unfold the side flaps (figure 12,6).
6. Connect the jack socket (figure 14,1) on the cable of the handheld remote to the jack plug (figure 14,2) on the drive. You will feel them click into place when properly connected.

5.5 Checking before use

1. Using the Up button (figure 15,3) raise the seat (see section 6.2). While doing so, check:
 - Can the seat move upwards freely?
 - Do the two side flaps rest on the edge of the bathtub when the seat is raised?
2. Using the Down button (figure 15,5) lower the seat fully (see section 6.3). While doing so, check:
 - Can the seat move downwards freely?
 - Is there a distance of at least 25 mm (0.98 in.) between the handheld remote connection and the wall?

Check that the bath lift is undamaged.

Check that the bath lift is correctly assembled and safely installed in the bathtub.

If the bath lift is correctly installed in the bathtub, do not change the position of the bath lift.

6 Operating the bath lift

6.1 Handheld remote

The bath lift is operated exclusively using the handheld remote (figure 15,4).

The handheld remote can be operated by the patient themselves or by a carer depending on the patient's physical condition.

NOTICE Only press the buttons on the handheld remote when the backrest is correctly mounted on the seat unit.

If the battery in the handheld remote is not sufficiently charged, the red LED (figure 15,2) will light up when the Down button (figure 15,5) is pushed. The seat can no longer be lowered. The seat can still be raised to the Exit position. After raising the lift, charge the battery in the handheld remote.

6.2 Raising the seat

NOTICE Take care not to jolt or bump the seat.

1. Press the Up button (figure 15,3). If the seat has been fully lowered, the backrest will first move into the upright position. Then the seat will move upwards.
2. To stop the seat in any position, let go of the Up button.
3. To raise the seat to the Exit position, press and hold down the Up button until the seat reaches the Exit position.

6.3 Lowering the seat

NOTICE Take care not to jolt or bump the seat.

1. Press the Down button (figure 15,5). The seat will move downwards.
2. To stop the seat in any position, let go of the Down button.
3. To lower the seat completely, press and hold down the Down button. When the seat is fully lowered, the backrest will move backwards to a maximum angle of 40°.

6.4 EMERGENCY STOP function

1. If the seat does not stop immediately after releasing the Up button (figure 15,3) or the Down button (figure 15,5):

Press the EMERGENCY STOP button (figure 15,1) or disconnect the plug connection (figure 14,1) between the handheld remote and the drive. The seat will stop moving immediately.

If the EMERGENCY STOP button is pressed during a lowering movement, the Down button will be subsequently locked for approx. 15 seconds for reasons of safety. The seat can then only be moved upwards (using the Up button).

See section 9 for possible causes of faults and how to rectify them.

7 Bathing

WARNING If the seat cannot move freely and if the side flaps do not rest correctly on the rim of the bathtub when entering, there is a risk of slipping. Before bathing, check that the bath lift is working correctly. Before getting on the seat, check that the side flaps are resting correctly on the rim of the bathtub.

NOTICE Bath salts or bath oils can impair the gliding ability of the scissor lift if excessive amounts are used. If using bath salts or bath oils, follow the manufacturer's recommended dosages.

NOTICE The drive is resistant to jets of water, but not to being submerged. Do not immerse the drive in water.

1. Move the seat upwards using the Up button (figure 15,3) until the side flaps (figure 16,1 and 2) lie flat on the bathtub rim.
2. Fill the bath with water and check the temperature of the water.
3. Sit on the front side flap (figure 16,1), with the back pointing towards the side flap on the opposite side (figure 16,2).
4. Slide to the centre of the seat plate and turn to the correct sitting position. To do so, lift one leg at a time over the bathtub rim. If necessary, use a swivel aid or a swivel/transfer aid (accessories).
5. Press the Down button (figure 15,5) until the seat reaches the desired position (see section 6.3).
6. After bathing, press the Up button (figure 15,3) until the seat reaches the Exit position (side flaps lying flat on the bathtub rim).
7. Turn into the Exit position. To do so, lift one leg at a time over the bathtub rim.
8. Slide onto the front side flap (figure 16,1).

8 Disassembling the bath lift

1. Drain the water completely from the bathtub.
2. Using the Down button (figure 15,5) lower the seat fully (see section 6.3).
3. Disconnect the jack socket (figure 14,1) on the cable of the handheld remote completely from the jack plug (figure 14,2) on the drive.
4. Fold in the side flaps (figure 12,6).

NOTICE If the drive unit foot is not fully retracted and the backrest is moved forwards, the bath lift may be damaged. Make sure that the drive unit

foot is completely retracted. The drive unit foot (figure 7,4) must be horizontal (see figure 7).

5. Take hold of the backrest at the upper end and move it forwards onto the seat unit.
6. Remove the backrest. To do so, take hold of the backrest (figure 7,1) with both hands close to the locking hooks (figure 7,2). Release the locking hooks from the holder (figure 7,3) by tugging gently.
7. Take hold of the handle on the front end of the base plate (figure 1,8).

NOTICE Do not detach the suction feet from the floor of the bathtub by force. This can damage the suction feet.

8. Pull the tabs of the two rear suction feet upwards. The suction feet will detach from the bathtub floor.
9. Slightly raise the rear end of the seat unit. The front suction feet will automatically detach from the bathtub floor.

CAUTION The drive unit foot mount contains the mechanism for releasing the seat plate lock. If the seat plate lock is accidentally released, the scissor lift can move freely. Limbs can be trapped and bruised. Do not reach into the drive unit foot mount (figure 7,5).

10. Lift the seat unit out of the bathtub and put it down safely. Take care not to damage or deform the suction feet when doing so.

9 Troubleshooting

If the bath lift does not function properly, the following table provides information on faults and their possible causes. If you cannot rectify a fault using the measures shown here, contact an authorised specialist dealer.

Do not open the handheld remote. The battery in the handheld remote cannot be replaced. Opening the handheld remote renders the warranty void.

Fault	Possible cause	Remedy
The red LED (figure 15,2) in the handheld remote flashes for 5 seconds	Handheld remote not correctly plugged into the drive	Push the jack socket (figure 14,1) fully onto the jack plug (figure 14,2)
The red LED (figure 15,2) in the handheld remote lights up	Battery empty	Charge the battery (see section 5.1)

Fault	Possible cause	Remedy
Seat only moves upwards	Battery empty	Charge the battery (see section 5.1)
Seat does not move	Battery empty	Charge the battery (see section 5.1)
	Drive malfunction	Have the device repaired by a specialist workshop
	Cable of handheld remote defective	Replace the handheld remote
Battery cannot be charged	Battery defective	Have checked/replaced by a specialist workshop
	Power supply unit defective	

10 Maintenance and care

10.1 Cleaning the seat unit and backrest

CAUTION Limbs can be crushed in the area of the scissor lift. Do not reach into the scissor lift.

NOTICE If the drive is cleaned using a pressure washer, water may penetrate the drive. This can damage the drive. Do not clean the drive using a pressure washer.

NOTICE The drive is resistant to jets of water, but not to being submerged. Do not immerse the drive in water.

If the bath lift is being used in a long-term care environment or in a clinical environment and must be cleaned and disinfected, please read the manufacturer's preparation and hygiene guidelines and observe in-house procedures.

Unbutton the seat and backrest covers (accessories), if present, and wash these in a washing machine (max. 40°C (104 °F)). Do not dry the covers in a tumble drier.

Rinse the bath lift (without covers) with warm water after each bathing session.

If the bath lift is heavily soiled, clean using standard cleaning agents (without solvents and with a pH value of 5-9) and a brush. Follow the instructions of the cleaning agent manufacturer.

After cleaning, dry the bath lift using a clean cloth.

10.2 Cleaning the handheld remote and charger

⚠ CAUTION Disconnect the charger from the mains power supply before cleaning. Do not clean the charger using water or immerse it in water.

NOTICE If the handheld remote is cleaned using a pressure washer, water may penetrate the handheld remote. This can damage the handheld remote. Do not clean the handheld remote using a pressure washer.

NOTICE Do not open the handheld remote.

Clean the charger using a dry cloth.

Clean the handheld remote using a damp cloth and then dry it.

If the bath lift is not used over longer periods, recharge the battery in the handheld remote at regular intervals (see section 5.1).

10.3 Disinfecting

⚠ WARNING The bath lift must be disinfected before every change of user. There is a risk of infection.

When disinfecting, follow the instructions for use and processing issued by the manufacturer of the cleaning agent and disinfectant.

Wipe down or spray all parts thoroughly with a commercially available surface disinfectant. Disinfect surfaces that come into frequent contact with hands/skin, such as the seat surface and push handles, particularly carefully.

To select a material-compatible disinfectant, see the current list issued by the Robert Koch Institute at www.rki.de.

The following disinfectants are compatible with the materials:

- Aldehyde-free disinfectants based on alcohol (max. 70% propyl alcohol)

10.4 Maintenance and inspections

⚠ CAUTION Maintenance and inspections must not be performed while the bath lift is in use.

Before using the bath lift, always check it for visible external damage.

If a malfunction occurs or signs of wear appear, contact an authorised specialist workshop immediately.

Have a visual and functional inspection carried out by an authorised specialist workshop at least every 24 months. This will maintain the functional safety of the bath lift.

Have a visual and functional inspection carried out by an authorised specialist workshop before the bath lift is reused by other persons. If signs of material deterioration appear, the bath lift must no longer be used.

Have any necessary repairs carried out by an authorised specialist workshop.

11 Mounting accessories

11.1 Mounting the side flap diverters

⚠ WARNING If the bathtub is fitted with handles, the side flaps cannot lie correctly on the bathtub rim. There is a risk of slipping. In addition, the side flaps could be damaged by the handles. Secure all handles with side flap diverters.

1. Hang the side flap diverter (figure 17,1) over the handle (figure 17,2).
2. Fold out the side flap (figure 17,3).
3. Raise the seat using the Up button (figure 15,3). While doing so, check that the side flap is guided safely over the handle.

11.2 Mounting the height adapter

⚠ WARNING If the bath lift is loaded without all height adapters being fitted, the base plate may break. There is a risk of slipping. Always mount all 6 height adapters.

NOTICE If the height adapters are not fully screwed into the threaded sleeves and the bath lift is loaded, the base plate may be damaged. Screw the height adapters into the threaded sleeves as far as they will go. Screw the suction feet into the height adapters as far as they will go.

1. Remove the backrest and turn over the seat unit (see section 5.2).
2. Screw all 6 height adapters (figure 18,1) into the threaded sleeves in the base plate.
3. Screw the 6 suction feet (figure 18,2) into the height adapters.
4. Raise the seat using the Up button (figure 15,3). While doing so, check that the bath lift can be raised enough for the side flaps to rest correctly on the bathtub rim.

12 Warranty

Warranty services refer to all product defects which are verifiably attributable to material or manufacturing flaws. The warranty period is 24 months as of receipt of notification of readiness for shipping, but following delivery at the latest. Damage which has occurred due to natural wear, intent, and negligent or improper operation or usage is excluded from the warranty obligation. This also applies to the use of unsuitable care products, lubricating oils or greases.

13 Liability

The DIETZ GmbH is only liable if the product is used under the specified conditions and for the specified purpose. We recommend that the products be handled appropriately and cared for according to the instructions. DIETZ GmbH is not liable for damage caused by components and spare parts that have not been approved by DIETZ GmbH. Repairs must only be carried out by authorised specialist retailers or by the manufacturer itself.



Product group: Bath lift

Product: KANJO

User manual version 6.1 EN

Last update: 2024-12 (NHA)

DIETZ GmbH

Reutäckerstrasse 12

76307 Karlsbad

Germany

Tel.: +49 7248.9186-0

Fax: +49 7248.9186-86

info@dietz-group.de

www.dietz-group.de

Printing errors, mistakes, price and product changes reserved.

© DIETZ GmbH, Karlsbad

Not to be reproduced, whether in part or in whole, without the written approval of DIETZ GmbH, Karlsbad.